



Simply Engineered Better

# 351HT

Undercounter High Temperature  
Overflow Type Dishwashing Machine  
with Built-in Booster Heater



**NEW!**

## SPECIFIER STATEMENT

Specified unit will be Moyer Diebel 351HT undercounter high temperature dishwashing machine with built-in booster. Features include 14-1/2" door opening clearance, standard liquid detergent & rinse-aid dispensing pumps, top, side & rear panels. Unit will have standard pumped drain, rinse-sentry feature to ensure proper 180°F final rinse temperature and stainless steel rinse arms with removable end caps for easy cleaning. 1 yr. parts and labor warranty.



Project \_\_\_\_\_  
Item No. \_\_\_\_\_  
Quantity \_\_\_\_\_

## STANDARD FEATURES

- **ENERGY STAR® Qualified**
- Rinse sentry feature – Ensures proper 180°F final rinse temperature
- Counter-balanced, double skin door
- Clog-resistant filtering system
- Stainless steel rinse-arms with removable end caps
- Pumped drain
- Liquid detergent and rinse-aid dispensing pumps
- Top, side and rear panels
- 2 kW tank heater
- Flexible fill and drain
- Pressure regulating valve
- Top mounted detergent and rinse-aid prime switches
- Low 0.85 US gal. water usage per rack
- Energy efficient – 30 Amp. breaker only for 40°F rise (40 Amp. breaker only for 70°F rise)
- 120-second cycle time. 24 racks per hour capacity
- Complete with one peg and one flat bottom rack (20" x 20")

## OPTIONS & ACCESSORIES

- |   |             |
|---|-------------|
| <input type="checkbox"/> 70°F rise booster                            |             |
| <input type="checkbox"/> CST- Combination sink/table Machine on right | P/N 403561  |
| <input type="checkbox"/> CST- Combination sink/table Machine on left  | P/N 403562  |
| <input type="checkbox"/> Flat bottom dishrack                         | P/N 101273  |
| <input type="checkbox"/> Peg dishrack                                 | P/N 101285  |
| <input type="checkbox"/> 6" Stand                                     | P/N 0712393 |
| <input type="checkbox"/> 17RS – 17" Stand                             | P/N 0708757 |



Simply Engineered Better

# 351HT

Undercounter High Temperature  
Overflow Type Dishwashing Machine  
with Built-in Booster Heater

Dimensions shown in inches

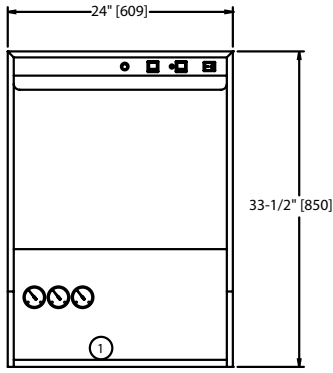

**Front View**

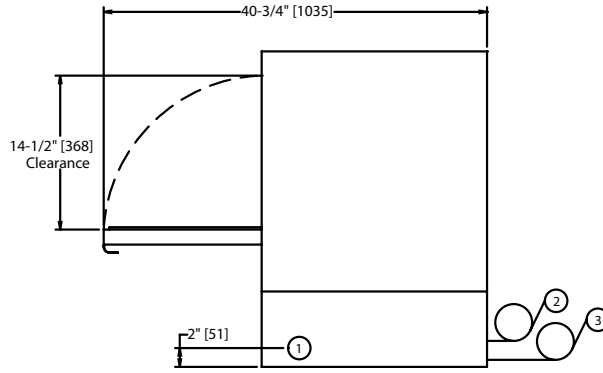

**Side View**

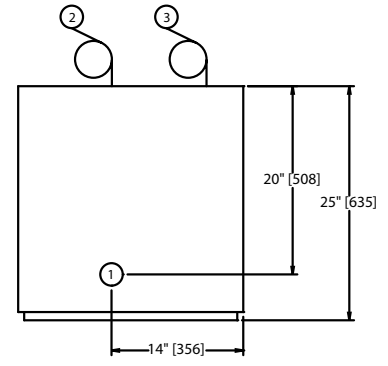

**Plan View**

Utilities	
<b>1 Electrical</b>	208-240/60/1; 3 wire + ground; hard wiring required (see boxes below)
<b>2 Hot Water</b>	<b>140°F Min., connection for 40°F rise booster.</b> <b>110°F Min., connection for 70°F rise booster.</b> 5 ft. long 1/2" I.D. flexible fill hose with 3/4" garden hose type connection. Flow pressure: 18-22 psi (124-152 kPa), PRV supplied
<b>3 Drain Connection</b>	6 ft. long, 3/4" I.D. flexible hose. Max. drain flow: 8 US gpm

## SPECIFICATIONS

<b>Capacity</b>	NSF Racks per hr.	24
<b>Motor Horsepower</b>	Wash	1
<b>Water Consumption</b>	Gal. per hr. (max. use)	
	US gal.	20.4
	Gal. per rack	
	US gal.	0.8
<b>Temperatures °F</b>	Wash (minimum)	150
	Rinse (minimum)	180
<b>Heating</b>	Tank heat, electric (kW)	2
	Electric booster	
	(kW required for 40°F rise)	4
	(kW required for 70°F rise)	6
<b>Time Cycle in Seconds</b>	Wash	100
	Rinse	15
	Dwell	5
	Total	120

351HT with 40°F Rise Electric Booster

351HT with 70°F Rise Electric Booster

Elec. Specs	Rated Amps	Minimum Supply Circuit Ampacity	Maximum Overcurrent Protective Device
208/60/1	22	30	30
230/60/1	24	30	30

Elec. Specs	Rated Amps	Minimum Supply Circuit Ampacity	Maximum Overcurrent Protective Device
208/60/1	29	40	40
230/60/1	31	40	40

	Uncrated	Crated
<b>Height</b>	33-1/2"	39-1/2"
<b>Width</b>	24"	25"
<b>Depth</b>	25"	25-1/2"
<b>Ship Wt. lbs</b>	148	165

\* Front leveling feet provided.

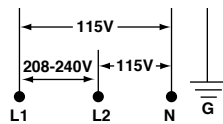

**\*Note:** Electrical supply service must be a 3-wire plus ground for connection as shown.

**Warning:** Plumbing and electrical connections should be made by qualified personnel who will observe all the applicable plumbing, sanitary and safety codes.