



Simply Engineered Better

201LT

Undercounter Low Temperature Dishwashing Machine



SPECIFIER STATEMENT

Specified unit will be Moyer Diebel Model 201LT undercounter low temperature dishwashing machine.

Features include 15-3/4" door opening, standard detergent, rinse-aid and sanitizer dispensing pumps. Wash tank heater maintains required water temperature.

1 year parts and labor warranty.



201LT UNDERCOUNTER

Project _____

Item No. _____

Quantity _____

STANDARD FEATURES

- **Soft Start** to protect glasses and dishes from chipping and breaking
- **Pumped Drain** permits use of the drain connection up to 6' of which 3' can be vertical
- **Energy Efficient** only 15 amp breaker required for 115v plug
- 25 Racks Per Hour*
- Fresh water wash and pumped rinse
- Built-in detergent, sanitizer and rinse-aid dispensing pumps
- Advance service diagnostics
- Upper and lower interchangeable spray arms
- Stainless steel top and side panels
- Counter balance door
- Wash tank heater
- Two 20" x 20" racks, one peg and one flat
- One year parts and labor warranty

* Excludes 30 second NSF load/unload time

OPTIONS & ACCESSORIES

- | | |
|---|---------------|
| <input type="checkbox"/> CST- Combination sink/table Machine on right | P/N 403561 |
| <input type="checkbox"/> CST- Combination sink/table Machine on left | P/N 403562 |
| <input type="checkbox"/> Flat bottom dishrack | P/N 101273 |
| <input type="checkbox"/> Peg dishrack | P/N 101285 |
| <input type="checkbox"/> 6" Stand | P/N 0712393 |
| <input type="checkbox"/> 17RS - 17" Stand | P/N 0708757 |
| <input type="checkbox"/> Site Glass kit | P/N 0712993 |
| <input type="checkbox"/> 1" roller casters | P/N 0712480-1 |
| <input type="checkbox"/> Low Chemical Alarm (factory installed) | P/N 0712314 |

Moyer Diebel - USA





Simply Engineered Better

201LT

Undercounter
Low Temperature
Dishwashing Machine

Dimensions shown in inches and [millimeters]

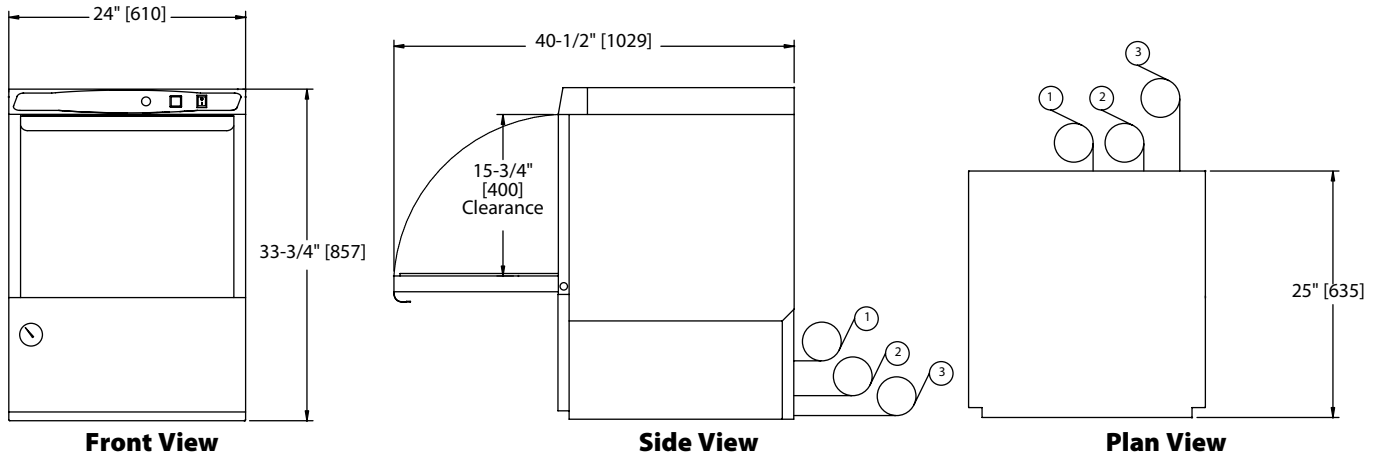

***Note:** Allow additional 3" clearance from wall.

Utilities	
1 Electrical	115/60/1; 12 amp draw; to be fused at 15 amp. 4ft. plug-in cord supplied.
2 Hot Water	120°F Min., 1/2" supply hot water connection (140°F recommended) 6 ft. long, 1/2" I.D. flexible fill hose with 3/4" hose connector Flow pressure: 25-95 psi (173-656 kPa)
3 Drain Connection	6 ft. long, 5/8" I.D. flexible drain hose Max. drain flow: 15 US gpm

	Uncrated	Crated
Height	33-3/4"	39-1/2"
Width	24"	25"
Depth	25"	25-1/2"
Ship Wt. lbs/kg	178	198
* Front leveling feet provided.		

SPECIFICATIONS	
Capacity	
*Racks per hr.	25
Motor Horsepower	
Wash	1
Water Consumption	
Per hr. (max. use)	32 US gal;
Per rack	1.5 US gal;
Temperatures °F	
Wash (minimum)	120 (140 recommended)
Rinse (minimum)	120 (140 recommended)
Heating	
Tank heat, electric (kW)	.75
Time Cycle in Seconds	
Wash	90
Rinse	26
Drain/fill	25
Total	141
* Excludes 30 second NSF load/unload time	

Warning: Plumbing and electrical connections should be made by qualified personnel who will observe all the applicable plumbing, sanitary and safety codes.