



Simply Engineered Better

Technical Manual



Undercounter
Dishwasher

Model

301HT

High Temperature
with Built-in Booster

Machine Serial No.

June, 2005

Manual P/N **113648** Rev H

P. O. Box 4183
Winston-Salem, North Carolina 27115-4149
336/661-1992 Fax: 336/661-1660

2674 N. Service Road
Jordan Station, Ontario, Canada L0R 1S0
905/562-4195 Fax: 905/562-4618

Complete the information below for quick reference.

Model Number _____ Serial Number _____

Voltage and Phase _____

Moyer Diebel Parts Supplier _____ Phone _____

Moyer Diebel Service Agency _____ Phone _____

Moyer Diebel Service:

Moyer Diebel (USA)

Phone: 1 (336) 661-1556

1 (800) 858-4477

Fax: 1 (336) 661-1660

Moyer Diebel Limited (Canada)

Phone: 1 (905) 562-4195

1 (800) 263-5798

Fax: 1 (905) 562-4618

Note: When calling to order parts, be sure to have the model number, serial number, voltage and phase of your machine.



AFTER S/N 45420

Machine Data Plate with model & serial number located on the lower left side of the machine.

S/N 45368-45419

Machine Data Plate with model & serial number located on the lower right side of the machine.

Revision Record

Revision Date	Revised Pages	Serial Number Effectivity	Comments
7/3/03	All	—	First issue of manual and replacement parts lists
10/2/03	2, 30-31		Inserted pressure reducing valve information (107550).
10/14/03	22-23		Inserted rinse aid dispenser parts breakdown information.
10/14/03	33		Revised part number for solenoid valve.
2/11/04	16		Revised part number for door support.
8/4/04	14-15		Added new hardware for panels.
8/4/04	16-17		Added new hardware for control cabinet decal.
1/18/05	14		Added door gasket H36353.
1/18/05	16-17		Added part numbers for hardware.
1/18/05	21		Replaced P/N 436348 with 113604 and H36157 with 0510821.
1/18/05	23		Added P/N's for rinse aid and detergent labels.
1/18/05	31		Replaced P/N H33402 with 109985.
1/18/05	36-37	54257-54304	Added new control panel.
6/6/05	16-17	60605	Added new drawing and part numbers to door rod plate.

Revision Record (Cont.)

Limited Warranty

Moyer Diebel, P.O. Box 4183, Winston-Salem, North Carolina 27115, and P. O. Box 301, 2674 North Service Road, Jordan Station, Ontario, Canada L0R 1S0 warrants machines, and parts, as set out below.

Warranty of Machines: Moyer Diebel warrants all new machines of its manufacture bearing the name “Moyer Diebel” and installed within the United States and Canada to be free from defects in material and workmanship for a period of one (1) year after the date of installation or fifteen (15) months after the date of shipment by Moyer Diebel, whichever occurs first. [See below for special provisions relating to Model Series DF and SW.] The warranty registration card must be returned to Moyer Diebel within ten (10) days after installation. If warranty card is not returned to Moyer Diebel within such period, the warranty will expire after one year from the date of shipment.

Moyer Diebel will not assume any responsibility for extra costs for installation in any area where there are jurisdictional problems with local trades or unions.

If a defect in workmanship or material is found to exist within the warranty period, Moyer Diebel, at its election, will either repair or replace the defective machine or accept return of the machine for full credit; provided, however, as to Model Series DF and SW, Moyer Diebel’s obligation with respect to labor associated with any repairs shall end (a) 120 days after shipment, or (b) 90 days after installation, whichever occurs first. In the event that Moyer Diebel elects to repair, the labor and work to be performed in connection with the warranty shall be done during regular working hours by a Moyer Diebel authorized service technician. Defective parts become the property of Moyer Diebel. Use of replacement parts not authorized by Moyer Diebel will relieve Moyer Diebel of all further liability in connection with its warranty. In no event will Moyer Diebel’s warranty obligation exceed Moyer Diebel’s charge for the machine. The following are not covered by Moyer Diebel’s warranty:

- a. Lighting of gas pilots or burners.
- b. Cleaning of gas lines.
- c. Replacement of fuses or resetting of overload breakers.
- d. Adjustment of thermostats.
- e. Adjustment of clutches.
- f. Opening or closing of utility supply valves or switching of electrical supply current.
- g. Adjustments to chemical dispensing equipment.
- h. Cleaning of valves, strainers, screens, nozzles, or spray pipes.
- i. Performance of regular maintenance and cleaning as outlined in operator’s guide.
- j. Damages resulting from water conditions, accidents, alterations, improper use, abuse, tampering, improper installation, or failure to follow maintenance and operation procedures.

Examples of the defects not covered by warranty include, but are not limited to: (1) Damage to the exterior or interior finish as a result of the above, (2) Use with utility service other than that designated on the rating plate, (3) Improper connection to utility service, (4) Inadequate or excessive water pressure, (5) Corrosion from chemicals dispensed in excess of recommended concentrations, (6) Failure of electrical components due to connection of chemical dispensing equipment installed by others, (7) Leaks or damage resulting from such leaks caused by the installer, including those at machine table connections or by connection of chemical dispensing equipment installed by others, (8) Failure to comply with local building codes, (9) Damage caused by labor dispute.

Warranty of Parts: Moyer Diebel warrants all new machine parts produced or authorized by Moyer Diebel to be free from defects in material and workmanship for a period of 90 days from date of invoice. If any defect in material and workmanship is found to exist within the warranty period Moyer Diebel will replace the defective part without charge.

DISCLAIMER OF WARRANTIES AND LIMITATIONS OF LIABILITY. MOYER DIEBEL’S WARRANTY IS ONLY TO THE EXTENT REFLECTED ABOVE. CHAMPION MAKES NO OTHER WARRANTIES, EXPRESS OR IMPLIED, INCLUDING, BUT NOT LIMITED, TO ANY WARRANTY OF MERCHANTABILITY, OR FITNESS OF PURPOSE. MOYER DIEBEL SHALL NOT BE LIABLE FOR INCIDENTAL OR CONSEQUENTIAL DAMAGES. THE REMEDIES SET OUT ABOVE ARE THE EXCLUSIVE REMEDIES FOR ANY DEFECTS FOUND TO EXIST IN MOYER DIEBEL DISHWASHING MACHINES AND MOYER DIEBEL PARTS, AND ALL OTHER REMEDIES ARE EXCLUDED, INCLUDING ANY LIABILITY FOR INCIDENTALS OR CONSEQUENTIAL DAMAGES.

Moyer Diebel does not authorize any other person, including persons who deal in Moyer Diebel Dishwashing Machines to change this warranty or create any other obligation in connection with Moyer Diebel Dishwashing Machines.

FOREWORD

1. Read the instructions in this manual carefully. It contains important information on installation, operation, and safety.
2. Store this manual carefully for future reference.
3. After removing packing material, check for loose parts in dishracks.
4. Before switching the equipment on, make sure that the model data plate conforms to the electrical and water requirements supplied to this particular machine.
5. Installation should be carried out by qualified personnel according to the manufacturer's instructions. The installation of your machine must meet all applicable health and safety codes.
6. This equipment should be used for its intended purpose. Any other application should be considered improper and therefore dangerous.
7. Only trained personnel should operate this equipment.
8. Operators must strictly follow all hygienic requirements in the handling of clean dishware or cutlery.
9. Do not leave the machine in an environment at temperatures lower than 0°C/32°F.
10. This machine should not be washed with a direct water stream.
11. Only qualified personnel should access the control panel after disconnecting main power supply. Tag the disconnect indicating work is being performed on that circuit.
12. Noise level of the machine is less than 67dB.

The manufacturer declines any responsibility for any printing errors contained in this booklet.

The manufacturer also reserves the right to make any modifications to its products that do not affect the basic characteristics thereof.

TABLE OF CONTENTS	PAGE
Revision Record.....	i
Limited Warranty	iii
Forward.....	iv
<hr/>	
INSTALLATION	1
OPERATION	5
MAINTENANCE	7
REPLACEMENT PARTS	13
ELECTRICAL SCHEMATICS	41

LIST OF FIGURES

Figure 1	– Control Panel Detail	5
Figure 2	– Power Switch Position	7
Figure 3	– Drain Switch Position	7
Figure 4	– Hood and Tank	14
Figure 5	– Door Assembly	16
Figure 6	– Wash and Rinse Arms	18
Figure 7	– Tank Components	20
Figure 8	– Rinse Aid Dispenser	22
Figure 9	– Wash and Rinse Spray Arms	24
Figure 10	– Wash and Rinse Piping	26
Figure 11	– Pump/Motor Assembly	28
Figure 12	– Booster Assembly	30
Figure 13	– Fill Piping Assembly	32
Figure 14	– Control Panel (Prior to Serial Number 54256 and After 54305).....	34
Figure 15	– Control Panel (Serial Number Range 54257 to 54304)	36
Figure 16	– Control Cabinet	38

This Page
Intentionally
Left
Blank

GENERAL

This manual covers the **Moyer Diebel 301** undercounter high temperature dishwashing machine with built-in booster. Liquid detergent and rinse aid dispensing pumps are standard. Even though chemical dispensing settings are preset at the factory for average water conditions, to ensure maximum performance and best results, have your chemical supplier perform a water titration test and adjust dispensing pumps for your specific water conditions.

INSTALLATION AND MAINTENANCE

The following instructions are addressed to qualified personnel. Repairs should be performed by authorized personnel using parts supplied by the manufacturer.

**NOTE:**

Installation must allow for the ability to remove machine for servicing.

UNPACKING

**WARNING:**

Care should be taken when lifting the machine to prevent damage.

The machine is normally shipped on a skid enclosed by straps. When transporting the machine, use a lift truck or fork lift, positioning the box properly on the forks.

1. Immediately after unpacking your machine, inspect for any shipping damages. If damage is found, save the packing material and contact the carrier immediately.
2. Remove the dishwasher from the skid. Adjust the feet if required, then move the machine to its permanent location.
3. Level the machine (if required) by placing a level on the top of the machine and adjusting the feet. Level the machine front-to-back and side-to-side.
4. Remove any foreign material from inside of the machine.

**CAUTION:**

After locating your machine, it must meet with all local health codes. Consult your local health department representative to ensure compliance.

INSTALLATION (CONT.)

ELECTRICAL CONNECTIONS



NOTE:

Leave enough electrical cable behind the machine so that the dishwasher can be pulled forward a minimum of two feet to be serviced.



WARNING:

Electrical and grounding connections must comply with the National Electrical Code and/or Local Electrical Codes.



WARNING:

When working on the dishwasher, disconnect the electric service and tag it to indicate work is being done on that circuit.

1. The electrician should compare the electrical specifications on the machine electrical data plate (located in the control panel) to the electrical power supply before connecting the machine to the incoming service at a fused disconnect switch.



NOTE:

The 208-240V/60Hz/1PH electrical supply service for this machine must be a 2-wire plus ground service. For optional 208-240V/60Hz/3PH the electrical supply service must be a 3-wire plus ground service.

2. On the 208V-240V models, a knockout is provided at the rear of the junction box for electrical service connections. A fused disconnect switch or circuit breaker (supplied by user) is required to protect each power supply circuit.

PLUMBING CONNECTIONS



CAUTION:

Plumbing connections must comply with local health and plumbing codes.

Water Connections

1. Connect the hot water supply to the fill hose provided with a 3/4" NPT fitting.
2. Install a manual shut-off valve in the water supply line to accommodate servicing the machine. The shut-off valve should be the same size or larger than the supply line.
3. Install a 3/4" pressure reducing valve (PRV) (supplied with machine) in the water supply line, and set at 22PSI/151kPa.

INSTALLATION (CONT.)

PLUMBING CONNECTIONS (CONT.)

Drain Connections

1. Drain hose must be supported by bracket provided (shipped inside of machine).
2. The drain hose bracket must be mounted a minimum of 2 feet above the finished drain, either on the rear of the machine or on the wall.
3. The maximum height of the drain from the floor must not exceed 3 feet.
4. Connect the 3/4" I.D. flexible reinforced drain hose to a 1-1/2" wye (Y) drain fitting. Use a 3/4" hose adapter (supplied by others). Do not connect drain hose to a 90° drain fitting.

DETERGENT

The machine is equipped with an automatic detergent dispensing pump system.

1. Use a qualified detergent/chemical supplier for your detergent and rinse aid needs.
2. Your machine is supplied with a detergent dispensing pump that is internally wired and ready for use. Use a commercial grade liquid detergent and insert the red pickup tube into the detergent container. The pickup tube has a strainer on the end to prevent the crystallized chemical from clogging the supply lines.



CAUTION:

Always wash the hands under running water if they come into contact with the detergent and comply with the specific instructions pertaining to the specific type of detergent.



NOTE:

A nonchlorinated detergent is recommended for your dishwasher.

To prime the peristaltic pump:

1. Insert pump inlet hose into the detergent container.
2. Close machine door and switch machine on.
3. Allow wash tank to fill and run machine cycles until chemical enters machine.

RINSE AID

1. Use a qualified/chemical supplier for your rinse aid needs.
2. Insert the transparent tube into the container containing the rinsing agent.
3. Prime the rinse aid pump while machine is in cycle by pressing and depressing power button until the transparent tube has completely filled.
3. Start the machine as described the "OPERATION SUMMARY" on page 5. The dispenser will pump about 3cc of liquid from the container.

INSTALLATION (CONT.)

COMPLETING THE INSTALLATION

1. Recheck for and remove any foreign materials from inside the machine.
2. Center the scrap screens over the sump opening
3. After Plumbing and electrical connections are completed, check machine for water leaks by closing the door, then depressing the **ON** switch. This allows the tank to begin filling and to reach temperature.
4. Open the door and check the water level. The water level should be a two inches above the scrap screen.
5. Close the door (the machine has a door safety switch and will not start until the door is closed).

OPERATION

OPERATION SUMMARY

The following is a summary of your model 301HT dishwasher operating cycle:

1. The door must be closed to begin the cycle.
2. Pressing the **POWER** button begins to fill the wash tank.
3. When the correct water level has been reached the booster heater comes on.
4. Press and holding the **START** button starts the cycle.
5. The pump runs during the wash cycle for approximately 120 seconds. **The wash cycle duration is extended if the booster water temperature does not reach 180°F/82°C**
6. After a 5 second pause, the fill valve opens and the rinse cycle starts.
7. The machine rinses for 15 seconds. The cycle light turns off after 7 seconds indicating that the cycle is complete. **DO NOT** open the door until the cycle lamp turns off.
8. Open the door and remove the rack of clean ware.



Figure 1-Control Panel

OPERATION PROCEDURES

The operation of your dishwasher will be more efficient when these procedures are followed:

1. Check that the spray arms, overflow tube and scrap screens are in place.
2. Close the door. Press the **POWER** switch. The tank will begin to fill with water. **This procedure is only needed when the tank is empty.**
3. When the tank is full, check the wash tank temperature gauge. Minimum wash temperature is **66°C/150°F**.
4. Scrap and preflush all items to be washed, load items into rack. Wash only one layer of silverware in a rack at a time.



NOTE:

DO NOT OVERLOAD the rack.

5. Open the door and insert the rack into the machine.
6. Close the door. Press the **START** switch and hold for 1 second, then release. This will start the wash cycle. The cycle lamp will light and will remain on until the entire wash/rinse cycle has completed.



NOTE:

The machine may be stopped at any time during the cycle by opening the door. Closing the door resumes from the point where it was interrupted in the cycle.

OPERATIONS (CONT.)

MAINTENANCE

7. Check the rinse temperature during the final rinse. The final rinse must be 82°C/180°F minimum.
8. When the green cycle light turns off, the cycle is complete.
9. Open the door and remove the rack.
10. Repeat steps 4-9 for additional cycles. Machine operation is automatic.
11. Clean the scrap screens after every meal period. During heavy usage, the scrap screens should be cleaned more frequently.



CAUTION:

Poor machine performance and/or damage to the machine can occur if the scrap screens become clogged with soil or waste particles.

12. At the end of the day, any water in the tank should be drained pressing the **POWER** button to turn machine off and remove the overflow tube. Then press the **DRAIN** switch to activate the drain pump and completely drain the machine.



CAUTION:

DO NOT LEAVE WATER IN THE TANK OVERNIGHT. Water left in the tank overnight will allow chemicals to deteriorate the tank.

MAINTENANCE

The efficiency and life of your machine is increased by regularly scheduled preventive maintenance. A well maintained machine gives better results and service. An investment of a few minutes of daily maintenance will be worthwhile.

The best maintenance you can provide is to keep your machine clean. Should poor results occur: first drain, next clean the machine as described below in the **Daily-Every 8 Hours** procedure, then refill.

Intervals shown in the following schedules represent an average length of time between necessary maintenance. Maintenance intervals should be shortened whenever your machine is faced with abnormal working conditions, hard water, or multiple shift operations.

CLEANING SCHEDULE

•Meal Periods

1. Press power switch **OFF** (See Fig.2).
2. Remove the overflow tube and press and hold the **DRAIN** switch to drain the machine. (See Fig. 3)
3. Wipe the interior to remove any debris.
4. Clean the screens after every meal period and more frequently during heavy usage. Do not allow screens to become clogged with debris.
5. Inspect wash and rinse arms. Clean if necessary.
6. Replace overflow tube.
7. Close door.
8. Press the **POWER** button to refill machine. (See Fig. 2).

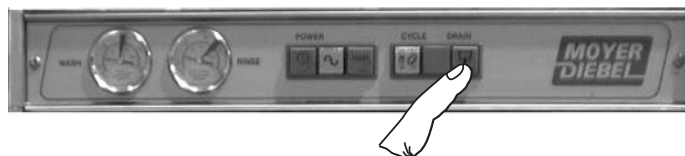

Figure 2- Power Switch Position

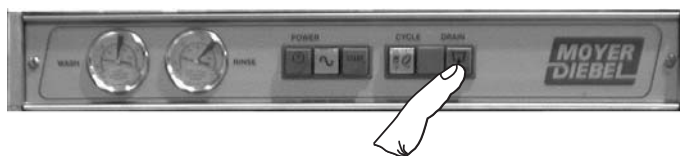

Figure 3- Drain Switch Position

•Daily-Every 8 Hours

1. Remove the overflow tube and press the **POWER** switch to **OFF** (see Fig. 2) to drain the tank.
2. Press and hold the **DRAIN** switch (see Fig. 3) to activate the drain pump and drain all the water from the machine.
3. Open the door and remove both the upper and lower spray arms by unscrewing the knurled fastener holding each arm.
4. Remove the scrap screen carefully to keep the debris from falling into the sump.
5. Clean the inside of the tank with clean water.
6. At a remote sink, back flush the screens until clean. Do not strike against solid objects.
7. Clean the wash and arms to remove any debris from the spray openings. Do not strike the arms against solid objects.
8. Reinstall the scrap screens, overflow tube and the spray arms.
9. Leave the door open overnight to allow drying.
10. Report any unusual conditions to your supervisor.

MAINTENANCE (CONT.)

CLEANING SCHEDULE (CONT.)

•As Required

1. Check temperature gauge readings. Replace as necessary.
2. Check chemical supplies and refill as necessary.

•Weekly

1. Inspect all water lines for leaks and tighten any joints if required.
2. Clean all detergent residue from exterior of machine.
3. Check drain for leaks.
4. Clean any accumulated scale from the heating element.
5. Remove and closely inspect each spray arm for any blockage.
6. Check for any damage to scrap screen. Ineffective screening can cause wash system failures.
7. Clean the detergent, and rinse aid supply tubes. Complete the following procedure:
 - a. Remove the detergent and rinse aid pick up tubes from the containers. Place the tubes into a container of hot water.
 - b. Remove the pick up tubes from the hot water and reinsert them into the correct chemical containers (red-detergent, clear-rinse aid). Repeat the original priming procedures to ensure that the chemicals have filled the tubes for the next operating period.
 - c. Run a complete cycle to flush chemicals from the tank.

MAINTENANCE (CONT.)

CLEANING SCHEDULE (CONT.)

DELIMING

Your dishwasher should be delimed regularly as required. This will depend on the mineral content of your water.

Inspect the machine interior for lime deposits. If deliming is required, a deliming agent should be used for best results.

Carefully follow the following procedure to preform deliming:



WARNING:

Deliming solution or other acids must not come in contact with household bleach (sodium hypochlorite) or any chemicals containing chlorine, iodine, bromine or fluorine. Mixing will cause hazardous gases to form. Skin contact with deliming solutions can cause severe irritation and possible chemical burns. Consult your chemical supplier for specific safety precautions.

1. Add the delime chemical to the wash tank (per the chemical supplier specifications).
2. Close the door.
3. Press the **POWER** switch to fill the machine, then press the **START** switch to run through a complete cycle.
4. When cycle is complete press the **POWER** switch to the OFF position, open the door and remove the overflow tube to drain the tank, then press and hold the **DRAIN** switch to drain the machine.
5. Replace overflow tube. Close door.
6. Repeat steps 3 - 5 to ensure all delime chemicals are purged from machine.
7. Deliming is now complete.

TROUBLESHOOTING

Before determining any specific cause of a breakdown or abnormal operation of your dishwasher, check that:

1. All switches are turned on.
2. Wash and rinse arms are clean and clear of any debris.
3. Overflow tube is properly positioned.
4. Scrap screen is properly positioned and clean.
5. Thermostats are at the correct settings.
6. Detergent and rinse additive dispensers are adequately filled.
7. All plumbing valves to machine are open.

If a problem still exists, use the following table for troubleshooting.

CONDITION	CAUSE	SOLUTION
Machine will not start	Main switch disconnected	Turn on switch.
	Door not closed	Make sure doors are fully closed.
	Door safety switch faulty	Contact your service agency
	Start switch faulty	Contact your service agency
Low or no water	Main water supply is turned off	Turn on house water supply
	Drain/overflow tube is not in place and seated	Place and seat drain/overflow tube
	Machine doors not fully closed	Close doors securely
	Faulty fill valve	Contact your service agency
Continuous water filling	Fill valve will not close	Contact your service agency
	Drain/overflow tube not in place ...	Install drain/overflow tube in tank
	Air trap lost pressure	Drain machine, reinsert overflow tube and refill machine.
Motor not running	Defective motor	Contact your service agency
Wash tank water temperature is low when in use	Incoming water temperature at machine too low	Raise temperature to 140°F
	Defective thermometer	Check or replace
	Defective thermostat	Check for proper setting or replace
	Defective heater element	Check or replace

TROUBLESHOOTING (CONT.)

CONDITION	CAUSE	SOLUTION
Insufficient pumped spray pressure	Clogged pump intake screen	Clean
	Clogged spray pipe	Clean
	Scrap screen full	Must be kept clean and in place
	Low water level in tank	Check drain and overflow tube
	Defective pump seal	Contact service agent
Insufficient final rinse or no final rinse	Clogged rinse nozzle and/or arm	Clean with paper clip/delime
	Clogged strainer.....	Clean or replace
Low final rinse temperature	Low incoming water	Check the booster be sure the thermostat is set to maintain 180°F/82°C temperature. Check fill valve operation.
	Defective thermometer	Check for proper setting or replace
Poor washing results	Detergent dispenser not operating properly	Contact detergent supplier
	Insufficient detergents	Contact detergent supplier
	Food Soil concentration too high in wash tank	Drain tank, clean and refill every 2 hours of operation or after each meal period.
	Wash water temperature too low	See condition "Wash Tank Water Temperature" above
	Wash arm clogged	Clean
	Wash arm not rotating	Clean arm. Check bearing, replace if necessary.
	Improperly scrapped dishes	Check scrapping procedures
	Ware improperly placed in rack	Use proper racks. Do not overload racks
	Improperly cleaned equipment	Unclog wash sprays and rinse nozzles to maintain proper pressure and flow conditions. Overflows must be open. Keep wash water as clean as possible.
	Heating element has soil/lime buildup	Clean and/or delime.
Detergent pick up tube in incorrect container	Place <u>RED</u> pick up tube in detergent container.	

**This Page
Intentionally
Left
Blank**

REPLACEMENT PARTS

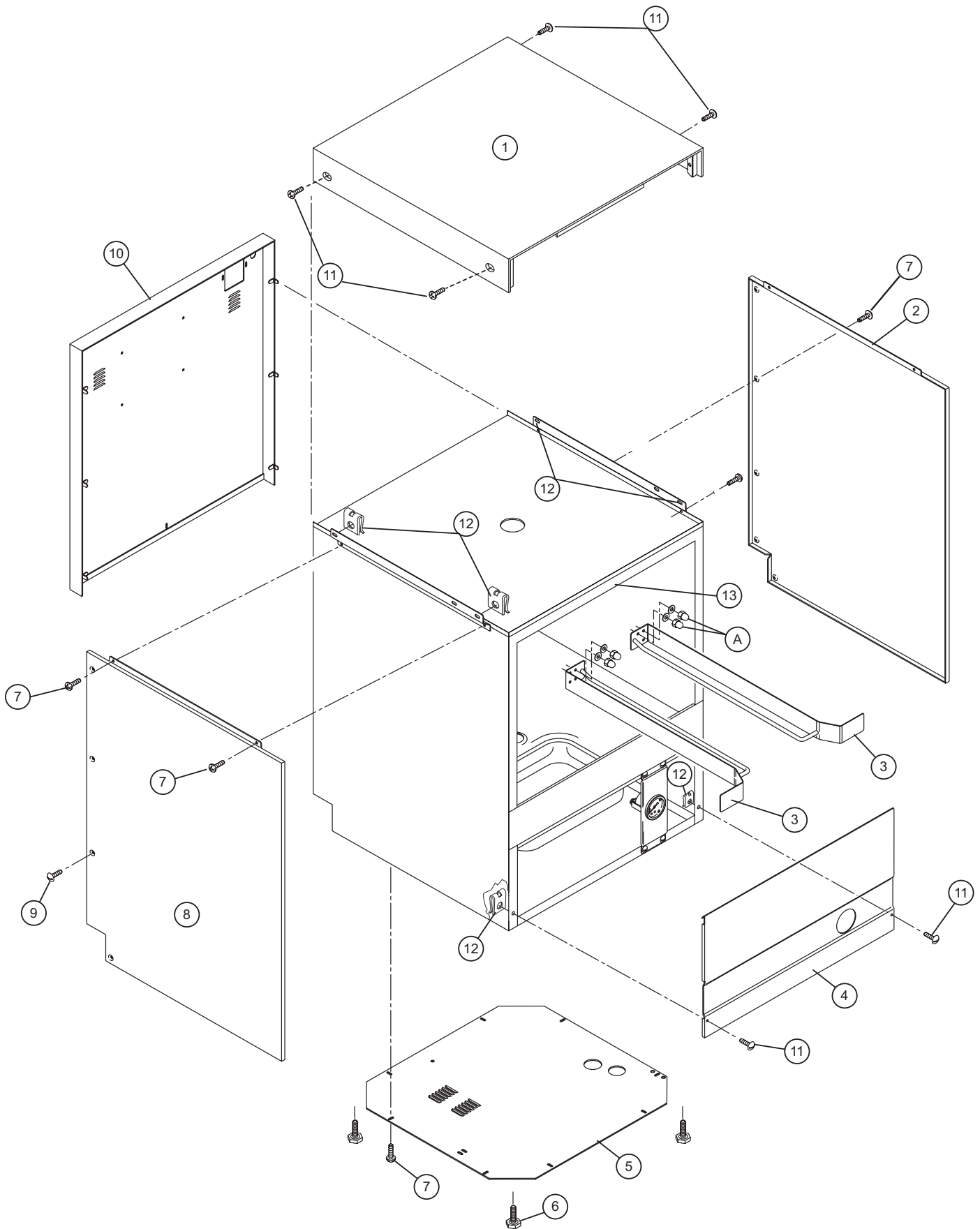

Figure 4- Hood and Tank

HOOD AND TANK

Fig. 4 Item No.	Part No.	Part Description	Qty
1	H36145	Panel, Control Cabinet	1
2	H36147	Panel, Side RH	1
3	H35551	Tracks, Rack	2
4	H36151	Panel, Front	1
5	H33576	Bottom Panel	1
6	H25209	Foot, Adjustable	4
7	H25697	Self-Tapping Screw 9 x 13	12
8	H36146	Panel, Side LH	1
9	H25693	Self-Tapping Screw Bevel 2 x 13	4
10	H36148	Panel, Back	1
11	H36728	Screw TS M5 x 20	6
12	H450821	Spring Clip Fastener 5MA	8
13	H36353	Door, Gasket Top	1

A **HARDWARE FOR TRACKS (Quantities per track)**

H25744	Washer	2
H25774	Nut	2

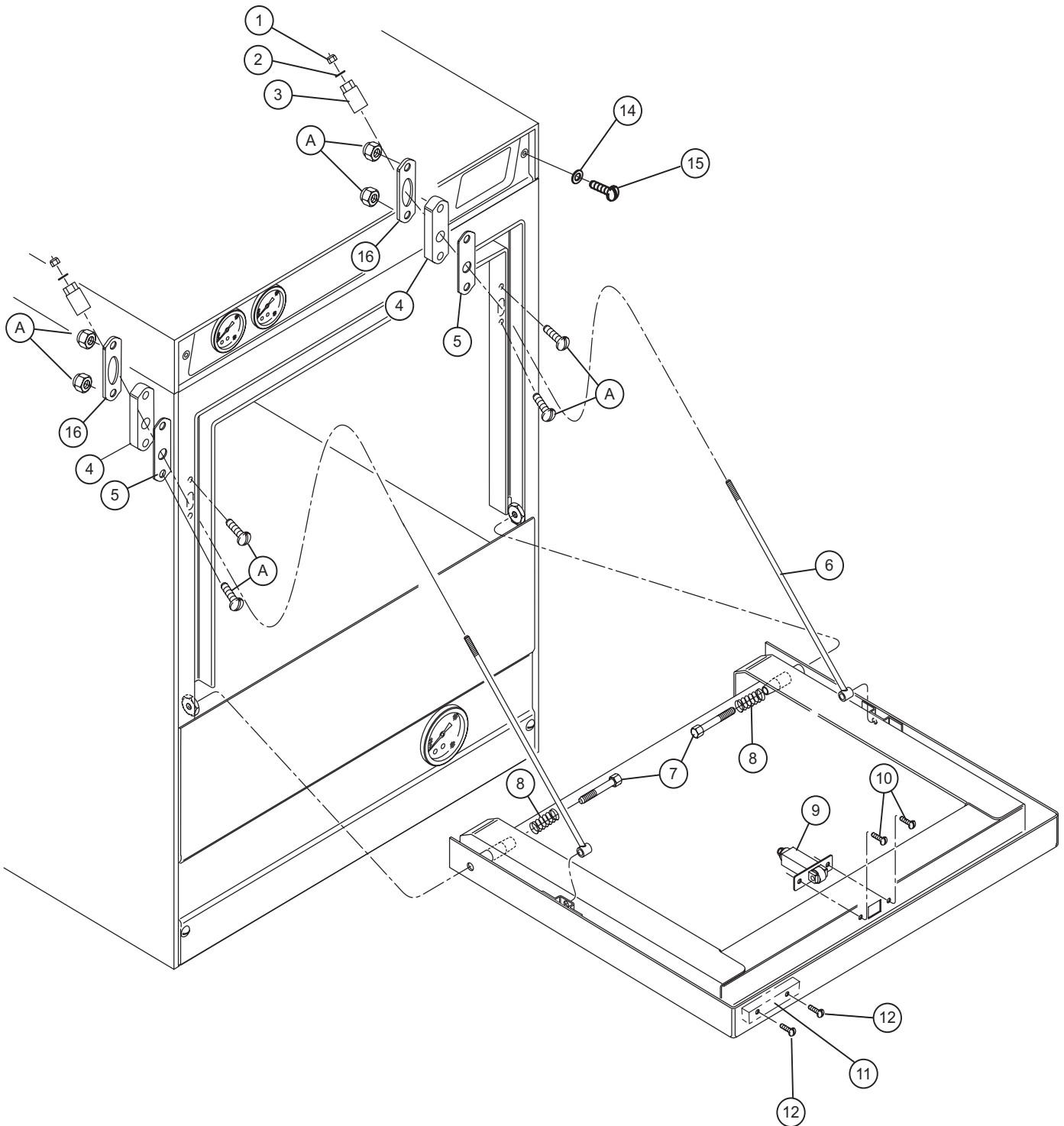

Figure 5- Door Assembly

DOOR ASSEMBLY

Fig. 5	Part	Part Description	Qty
Item No.	No.		
1	H25791	Nut Plain	2
2	106486	Washer	2
3	107623	Nut Door Support	2
4	H160909	Door Rod Plate	2
5	H160837	Gasket	2
6	H34144	Door Rod	2
7	H15568	Door Dowels	2
8	H30438	Door Spring	2
9	H33336	Door Catch	1
10	H25693	Self-Tapping Screw Bevel 2 x 13	2
11	H36149	Door Assembly Complete	1
12	H33277	Self-tapping Screw TSP 2.9 x 9.5	2
13	H32969	Door Magnet	1
14	H35171	Washer	2
15	H260223	Screw Inox TB 5 x 12	2
16	H37104	Door Rod Plate Support	2

A HARDWARE FOR DOOR PLATE (Quantities per door plate)

H33387	Screw	2
H30194	Hex, Nut	2

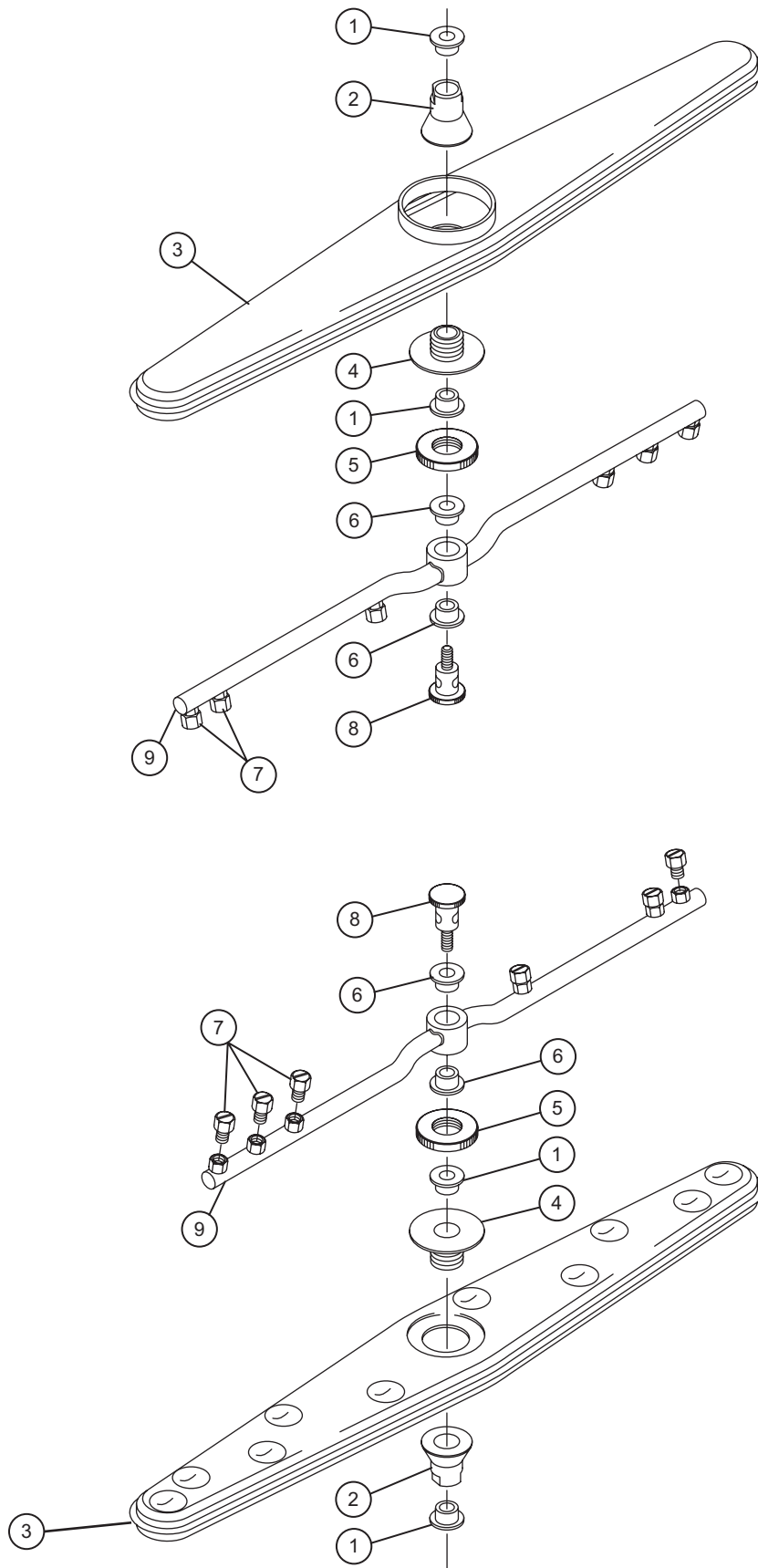

Figure 6- Wash and Rinse Arms

WASH AND RINSE ARMS

Fig. 6	Part	Part Description	Qty
Item No.	No.		
1	112551	Bearing, Wash Arm	4
2	112549	Hub, Wash Arm	2
3	112793	Wash Arm	2
4	112550	Locknut, Wash Arm	2
5	H34998	Nut Spacer	2
6	H190663	Bushing, Rinse Arm	4
7	H36257	Rinse Nozzle	6
8	H36275	Pin, Revolving Rinse Arm	2
9	H36211	Rinse Arm 301	2

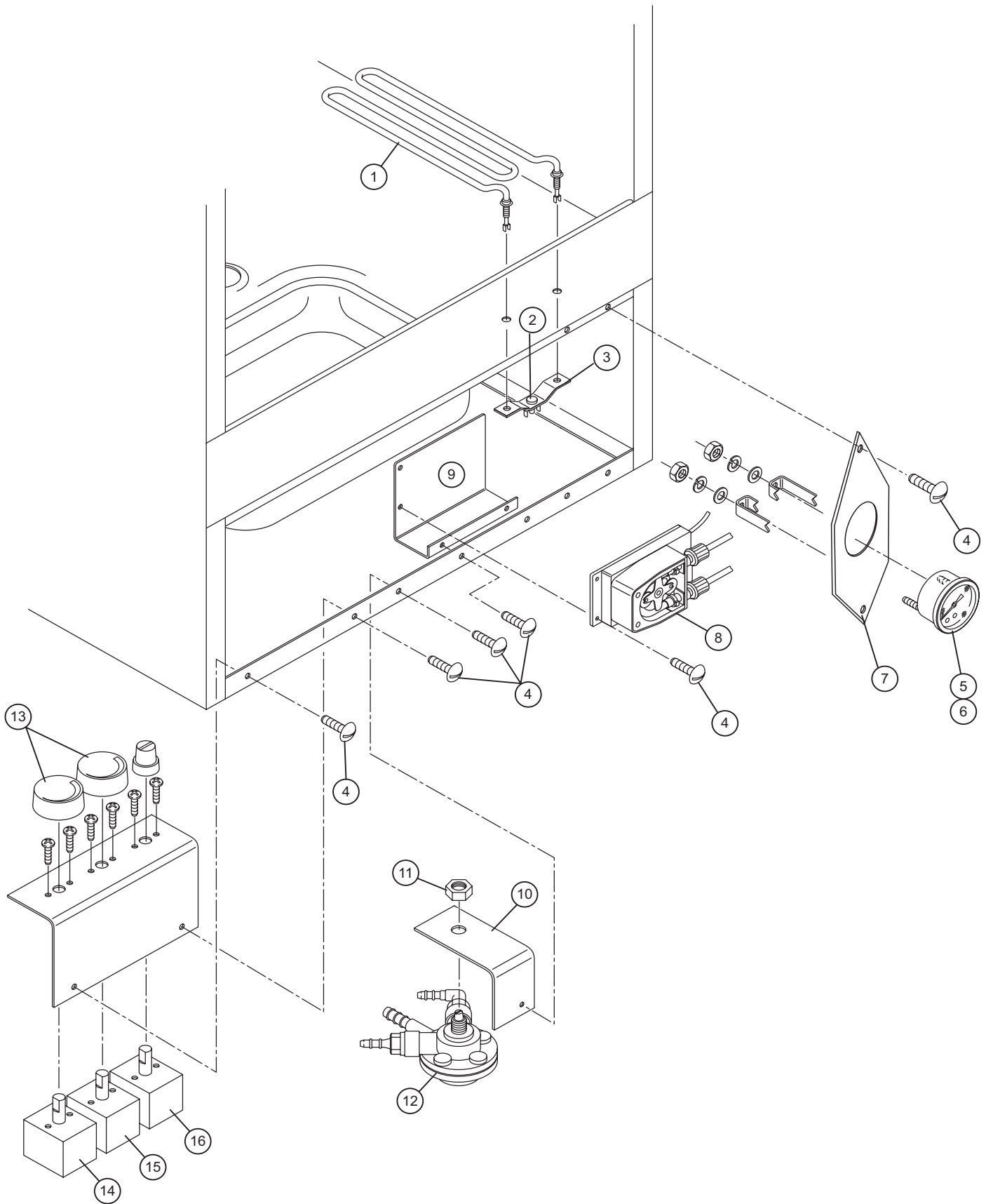

Figure 7- Tank Components

TANK COMPONENTS

Fig. 7 Item No.	Part No.	Part Description	Qty
1	H35162	Heater 2000W 230V	1
2	113604	Thermostat Handle	1
3	H36351	Support Plate, for Thermostat Handle	4
4	H34982	Screw M5 X 12 Half Round Head	A/R
5	H44140	Pressure Gauge	1
6	H460344	Plate Adhesive, Thermometer	1
7	H36154	Bracket, Pressure Gauge	1
8	H34358	Detergent, Peristaltic Pump	1
---	0510821	Hose, Noprene Pump 1/4 ID x 5/16	A/R
---	H180726	Strainer	1
9	H36271	Bracket, Detergent Pump	1
10	H36343	Bracket, Rinse Aid Pump	1
11	H15229	Lock Nut Aid	1
12	H35388	Rinse Aid Dispenser	1
---	H00166	Tube (Transparent)	A/R
---	H180726	Strainer	1
13	H25092	Knob, Thermostat	2
14	H25417	Adjustable Thermostat 30°C-90°C/86°F-194°F (Wash)	1
15	H36397	Thermostat 30°C-95°C/86°F-203°F(Rinse)	1
16	H33745	Hi Limit Thermostat	1

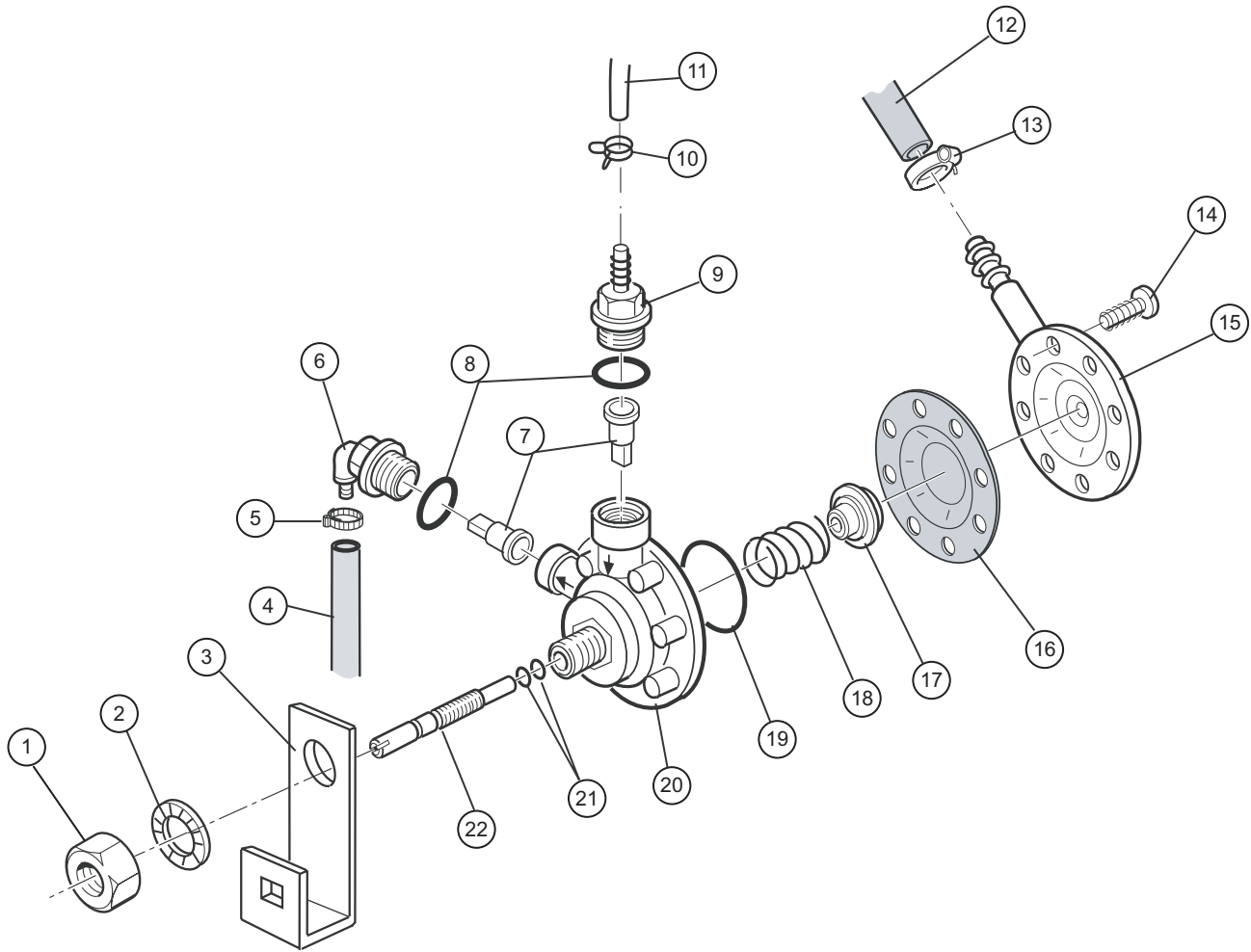

Figure 8- Rinse Aid Dispenser

RINSE AID DISPENSER

Fig. 8	Part	Part Description	Qty
Item No.	No.		
1	H15229	Locknut, Rinse Aid Dispenser	1
2	H25757	Spacer Slotted	1
3	H36343	Support, Rinse Aid Dispenser	1
4	H200117	Rubber Hose	A/R
5	H33424	Hose Clamp	1
6	H35392	90° Fitting Valve, Rinse Aid	1
7	H25211	Valve, Non Return Rinse Aid	2
8	H32831	Gasket	2
9	H28252	Dispenser Suction Fitting	1
10	H31643	Hose Clip	1
11	H00166	Hose, Transparent	A/R
12	H00182	Hose, Blue	A/R
13	H25803	Hose Clip 13-20 ABA	1
14	H32280	Screw, Rinse Aid Dispenser Pump Housing	8
15	H25047	Rinse Aid Dispenser Back Housing	1
16	H31596	Rinse Aid Dispenser Back Housing Gasket	1
17	H31991	Rinse Aid Pump Seal	1
18	H25818	Rinse Aid Dispenser Pump Spring	1
19	H32243	Gasket	1
20	H25046	Rinse Aid Dispenser Pump Housing	1
21	H25251	O-ring	2
22	H18394	Adjusting Screw, Rinse Aid Dispensing Pump	1
---	H35388	Rinse Aid Dispenser (Includes items 1-9, 14-22)	
---	H29521	Rinse Label	
---	H29522	Detergent Label	

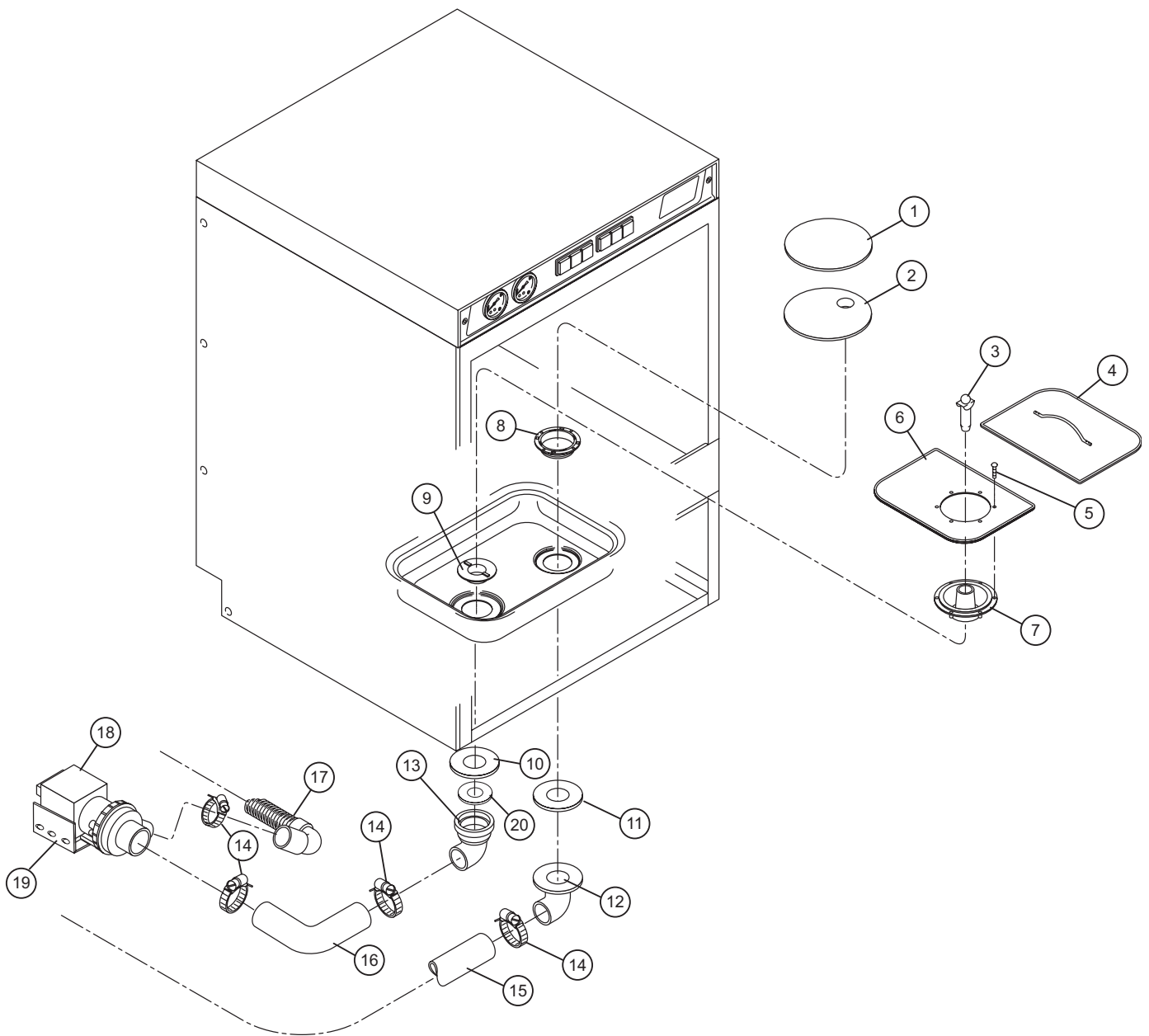

Figure 9- Drain Assembly

DRAIN ASSMEBLY

Fig. 9	Part		
Item No.	No.	Part Description	Qty
1	H32796	Cover, Round Filter	1
2	H32795	Bottom, Round Filter	1
3	H36160	Overflow Tube, Drain Pump	1
4	H35895	Scrap Screen	1
5	H25684	Self-Tapping Screw 9 x 9	1
6	H35896	Sump Cover	1
7	H32719	Rubber Sump	1
8	H25006	Nut, Drain Suction	1
9	H34790	Drain Elbow Series	1
10	H26637	Flat Gasket Drain	1
11	H31423	Flat Gasket Suction	1
12	H32715	90° Suction Elbow	1
13	H30421	Drain Fitting Long	1
14	H25807	Clamp, Hose	4
15	H32894	Suction Hose	1
16	H32801	Suction Sleeve, Drain Pump	1
17	H36032	Drain Pipe	1
18	H35544	Drain Pump	1
19	H35359	Bracket, Drain Pump.....	1
20	H28226	O-ring, Gasket	1

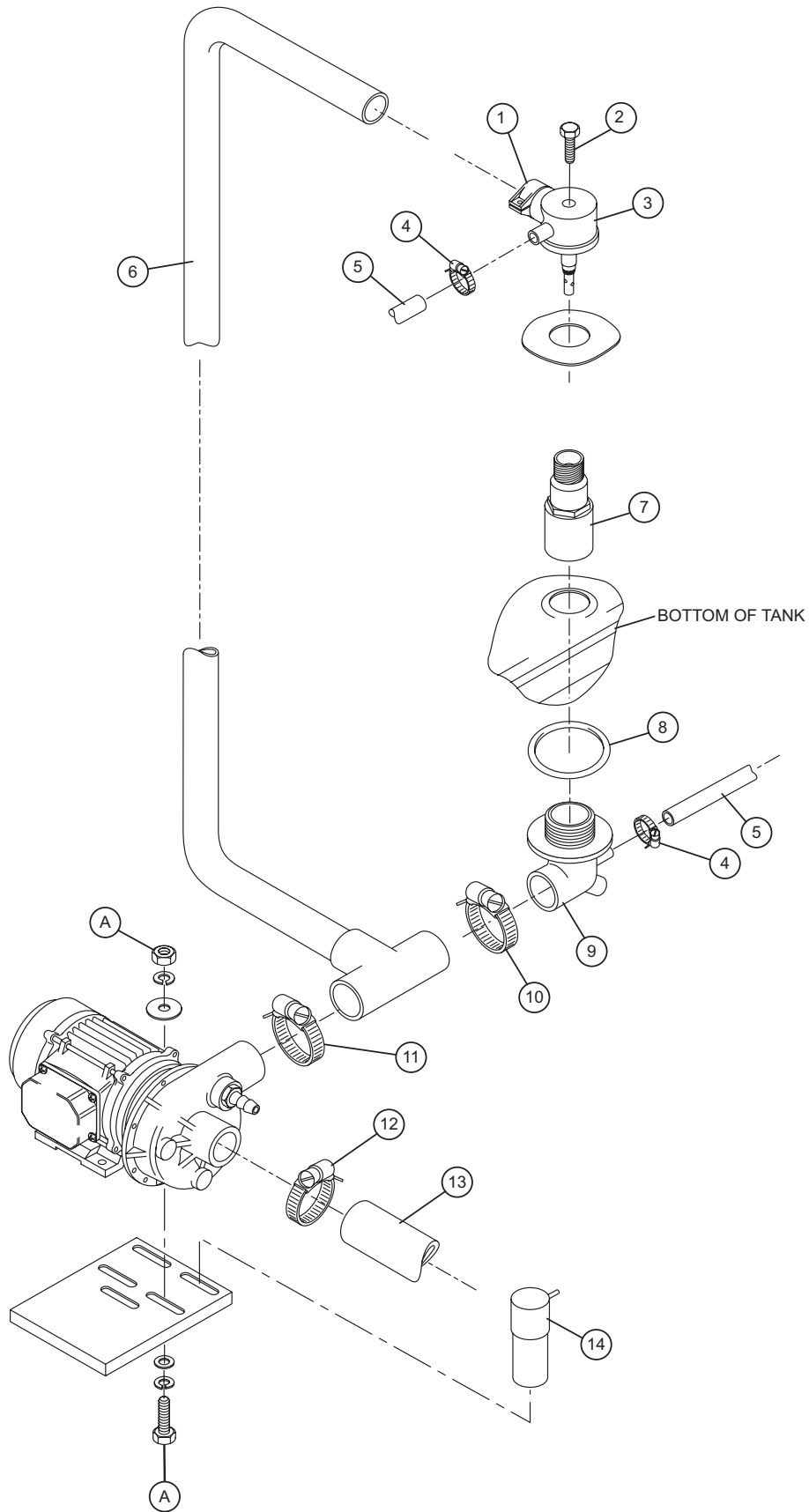

Figure 10- Wash and Rinse Piping

WASH AND RINSE PIPING

Fig. 10 Item No.	Part No.	Part Description	Qty
1	H25807	Jubilee Clip	1
2	110215	Screw SS	1
3	H35509	Hub, Upper Arm	1
4	H25803	Clamp, Hose	2
5	H00182	Hose, Blue Rinse	A/R
6	H35550	Wash Delivery Sleeve	1
7	H36279	Lower Column	1
8	109466	O-ring	1
9	H36280	Lower Holder Revolving Arm	1
10	H25808	Clamp, Hose	1
11	H34828	Clamp, Hose	1
12	H25809	Clamp, Hose	1
13	H32894	Suction Hose	1
14	H29043	Capacitor 16 UF/450V	1

A **HARDWARE FOR MOUNTING PUMP**

H25751	Split Spacer	8
H25745	Lock Washer	8
H25730	Hex Screw M8 x 25	4

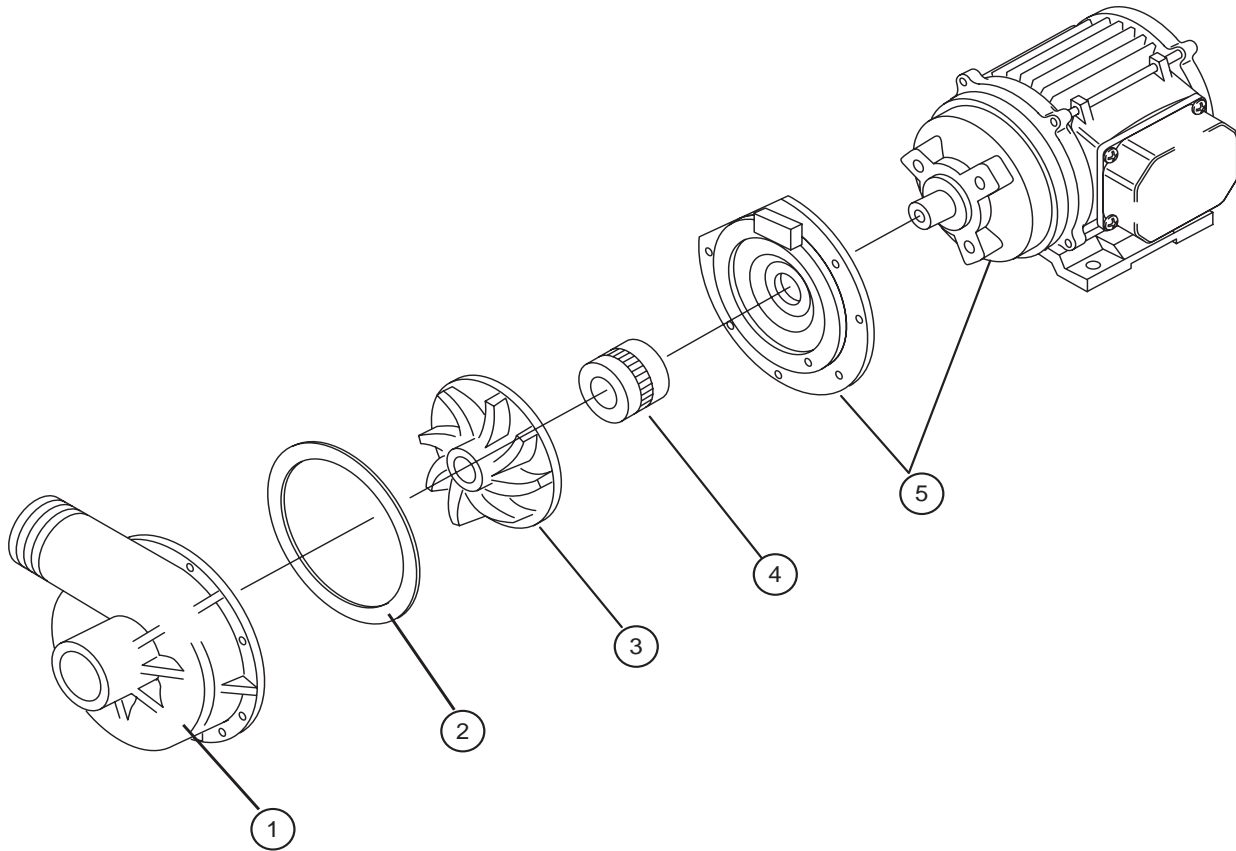

Figure 11- Pump Assembly

PUMP ASSEMBLY

Fig. 11	Part		
Item No.	No.	Part Description	Qty
1	H36354	Pump Body	1
2	H26224	Gasket Pump Body	1
3	H26204	Impeller	1
4	H36355	Shaft Seal	1
5	H36356	Flange Wash Pump.....	1
-	H36129	Wash Pump Assy Complete	1

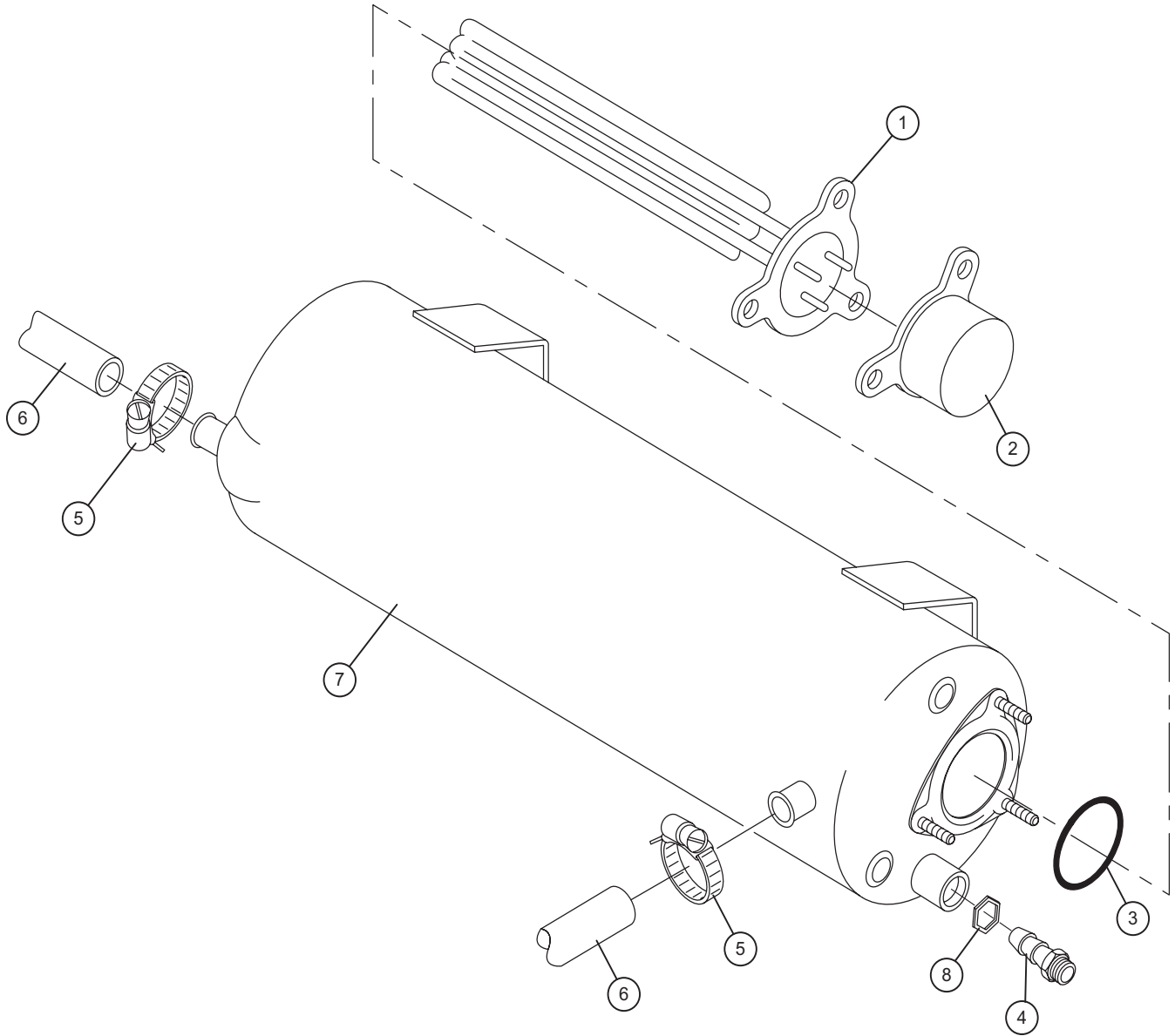

Figure 12- Booster Assembly

BOOSTER ASSMEBLY

Fig. 12	Part		
Item No.	No.	Part Description	Qty
1	H36250	Heater 4000W 230/380V (40° Rise)	1
	H33400	Heater 6000W 230/380V (70° Rise)	1
2	H161123	Element Cap	1
3	109985	Oring	1
4	H35816	Rinse Aid Inlet Fitting	1
5	H25803	Clamp, Hose	2
6	H00182	Hose, Blue	A/R
7	H36150	Booster Tank (Tank Only)	1
8	H34192	Gasket	1

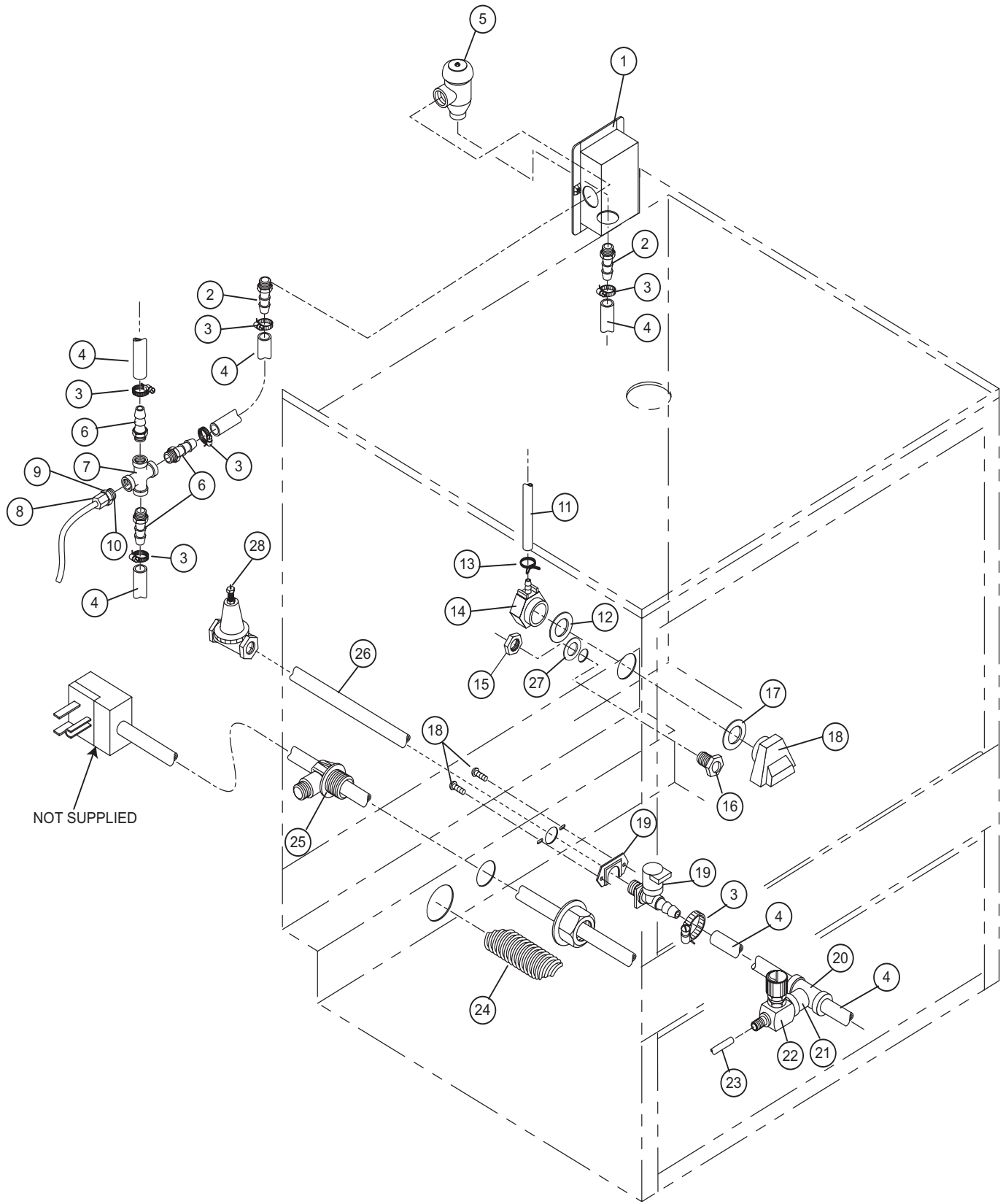

Figure 13- Fill Piping Assembly

FILL PIPING ASSEMBLY

Fig. 13 Item No.	Part No.	Part Description	Qty
1	H36156	Vacuum Breaker Mounting Box	1
2	H36361	Hose Barb	2
3	H25803	Clamp, Hose	A/R
4	H00182	Hose, Blue	A/R
5	100500	Vacuum Breaker 1/2"NPT	1
--	900836	Repair*Kit 1/2" Vacuum Breaker	A/R
6	H36170	Hose Barb	3
7	H36173	Cross Tee	1
8	H36289	Right for Brass Insert	1
9	H36288	Brass Insert	1
10	H36290	Raccord, Brass Insert	1
11	H160121	Hose Black	A/R
12	H25239	Gasket	1
13	H34733	Clamp	1
14	H25011	Cover for Air Trap	1
15	H25778	Nut, Injector	1
16	H18472	Detergent Injector	1
17	H25263	Flat Gasket	1
18	H25010	Air Trap	1
19	H26629	Solenoid Valve 3/4"	1
20	H36172	Fitting	1
21	H36349	Brass Reduction	1
22	H280607	Valve	1
23	H160117	Poly Tube	A/R
24	H36032	Drain Hose	1
25	H33344	Cable Clip	1
26	H34996	Inlet Tube	1
27	H200415	O-ring, Gasket	1
28	107550	Valve Press Reducing 3/4"	1

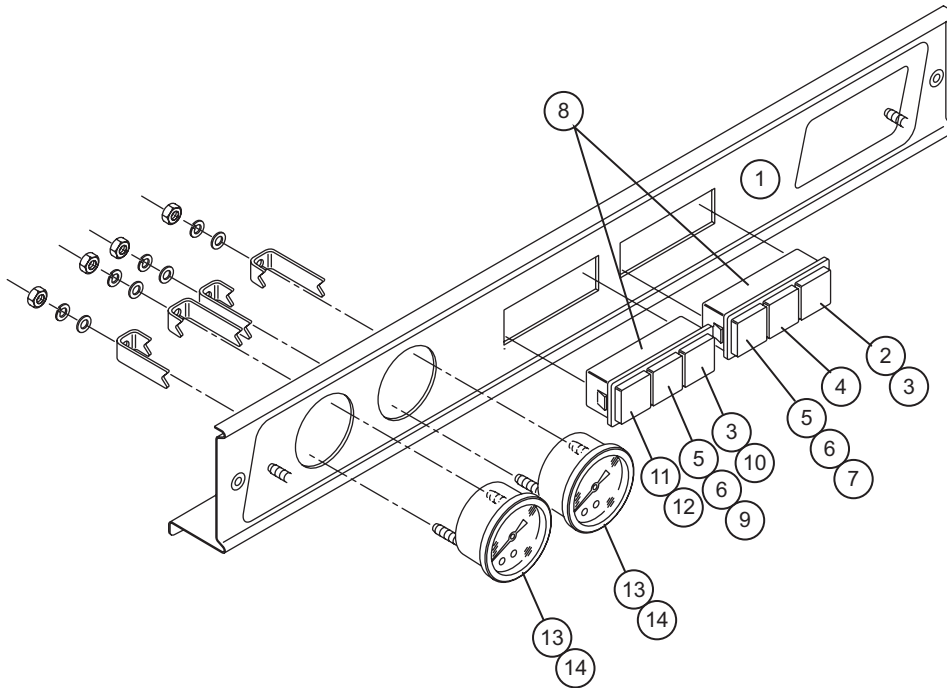

Figure 14- Control Panel
Prior to S/N 54256 & After S/N 54305

**CONTROL PANEL
(PRIOR TO 54256 & AFTER S/N 54305)**

Fig. 14 Item No.	Part No.	Part Description	Qty
1	H36131	Data Plate	1
2	H35336	Cap, Drain Pushbutton	1
3	H32928	Lamp Neon Green	2
4	H35339	Cap Blank	1
5	H32892	Neon Light Bulb Green	2
6	H32891	Light Bulb Holder	2
7	H35329	Lamp Cover Green, Cycle	1
8	H35332	Holder, 3 Position Gray	1
9	H35328	Lamp Cover Green, Line	1
10	H35330	Key, Green Start	1
11	H35661	On/Off Green Key	1
12	H32872	Switch Single Pole	1
13	H450916	Thermometer	2
14	H460344	Plate Adhesive, Thermometer	2

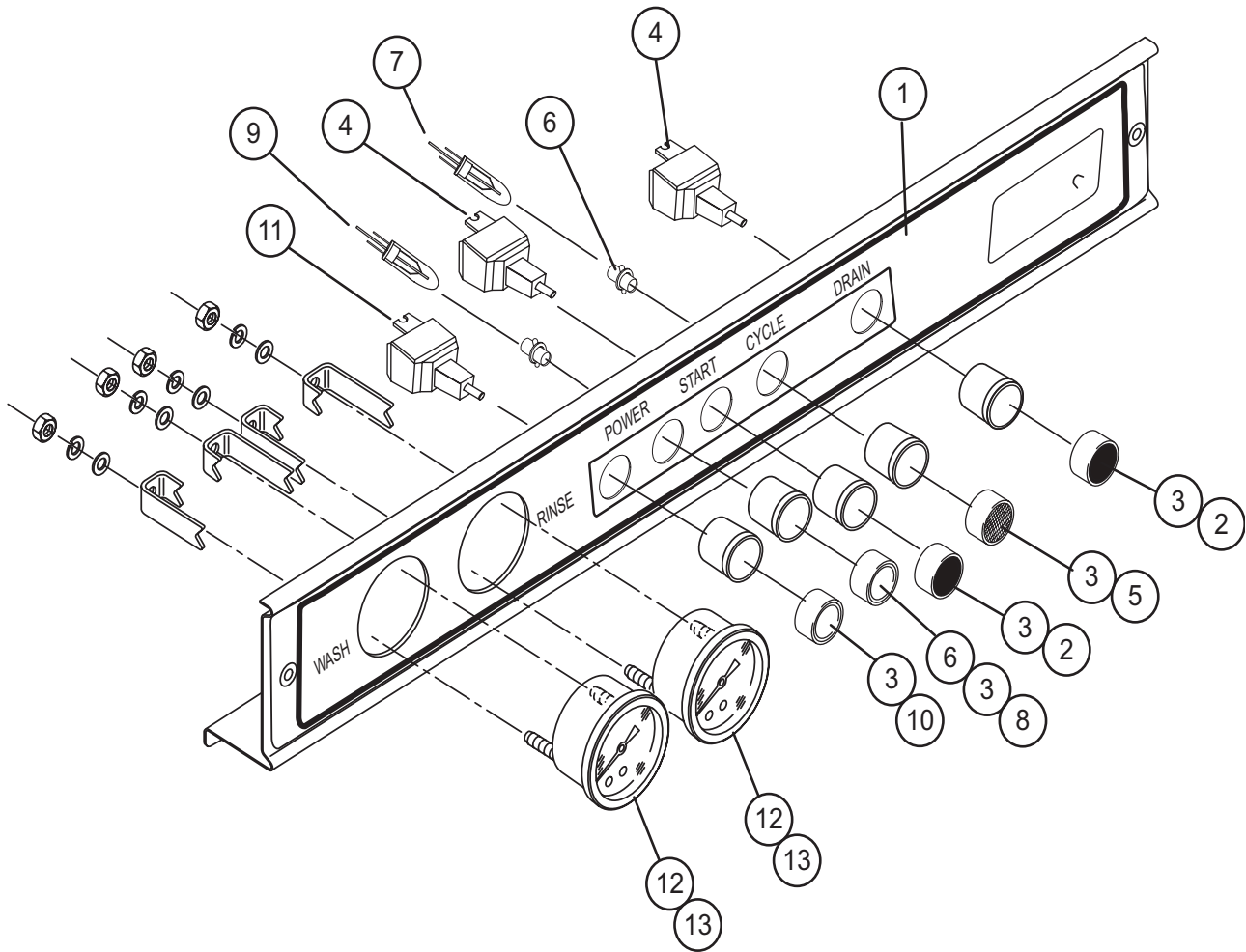

Figure 15- Control Panel
S/N Range 54256 to S/N 54304

**CONTROL PANEL
(S/N RANGE 54257 TO 54304)**

Fig. 15 Item No.	Part No.	Part Description	Qty
1	H36648	Data Plate	1
2	H36799	Key, Black Drain	2
3	H36795	Holder, D.25 Black	5
4	H36801	Push-button, Double Pole Shunt	2
5	H36798	Lamp Cover Clear D.25, Cycle	1
6	H32891	Light Bulb Holder	2
7	H28870	Light Bulb -Lux FM6, 3 230V	1
8	H36797	Lamp Cover Green d.25, Line	1
9	H32892	Neon Light Bulb Green	1
10	H36796	On/Off Green D 25 Key	1
11	H36800	Switch Single Pole	1
12	H450916	Thermometer	2
13	H450916	Plate Adhesive, Thermometer	2

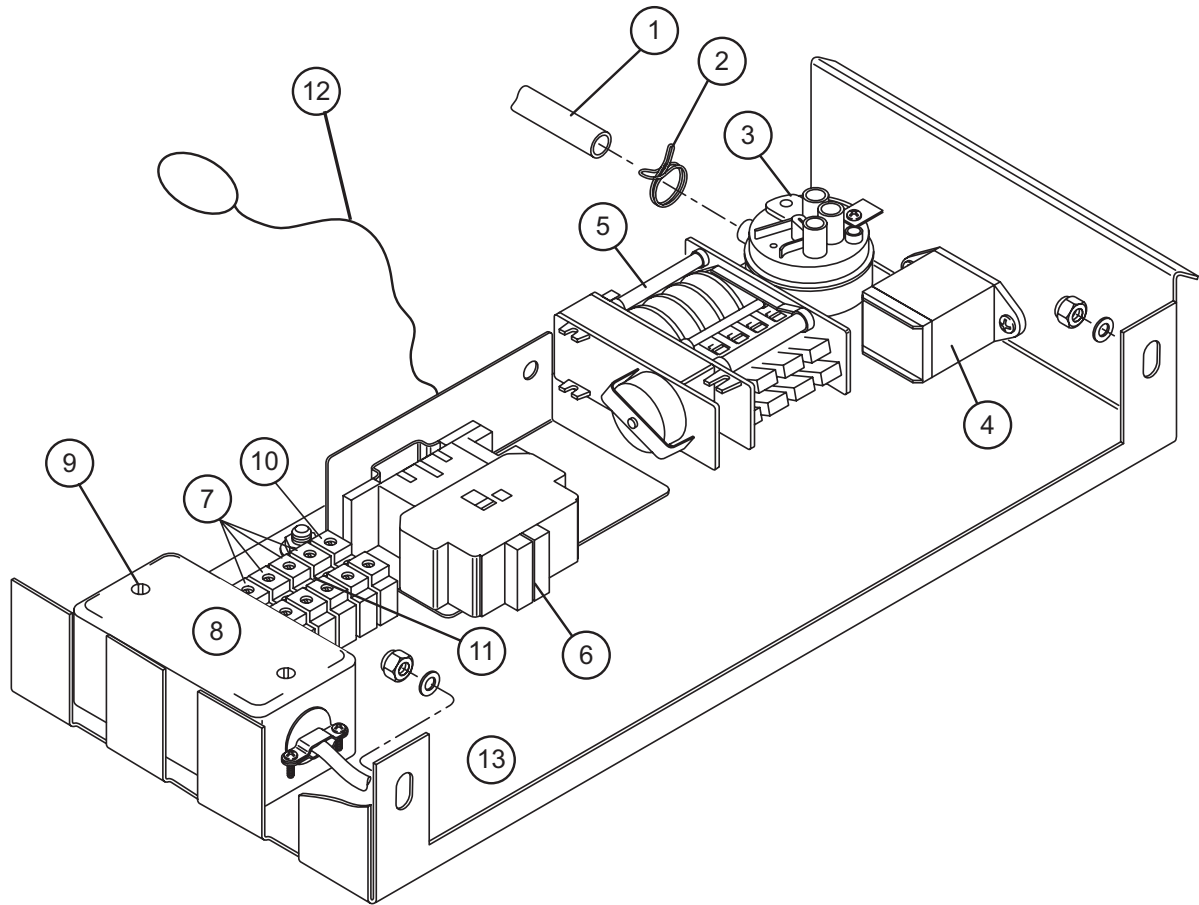

Figure 15- Control Cabinet

CONTROL CABINET

Fig. 15 Item No.	Part No.	Part Description	Qty
1	H160121	Hose, Black Rubber	1
2	H31643	Clamp, Hose	1
3	H31171	Pressure Switch	1
4	H34312	Relay TA2SFA 16A 230V	1
5	H36142	Timer 230V 60Hz	1
6	H31982	Booster Heater Contactor 220V 50Hz	1
7	H29175	Terminal Block	4
8	H36357	Switch, Continous Wash	1
9	H260248	Screw M5 x12	2
10	H29281	Terminal Block Earth (Ground)	1
11	H36278	Threaded Bar, Electrical Connection	1
12	H34046	Drawer Stop Rope (Not Shown)	1
13	H33188	Magnetic Switch (Not Shown)	1

This Page
Intentionally
Left
Blank

PART 4:
ELECTRICAL
SCHEMATICS

CUSTOMER TO SUPPLY RATED VOLTAGE PHASES AS SPECIFIED PER ORDER TO DISCONNECT SWITCH ALL POWER SUPPLIED TO EACH CONNECTION POINT MUST BE SUPPLIED TO EACH CONNECTION POINT BY THE SUPPLIER	SCALE	SCALE
DATE	3/10/03	SHEET SH1 OF 1

REV.	DESCRIPTION	DATE	BY

REV.	DESCRIPTION	DATE	BY



SCHMATIC, 301-HT SINGLE PHASE	REV
B 0510637	0

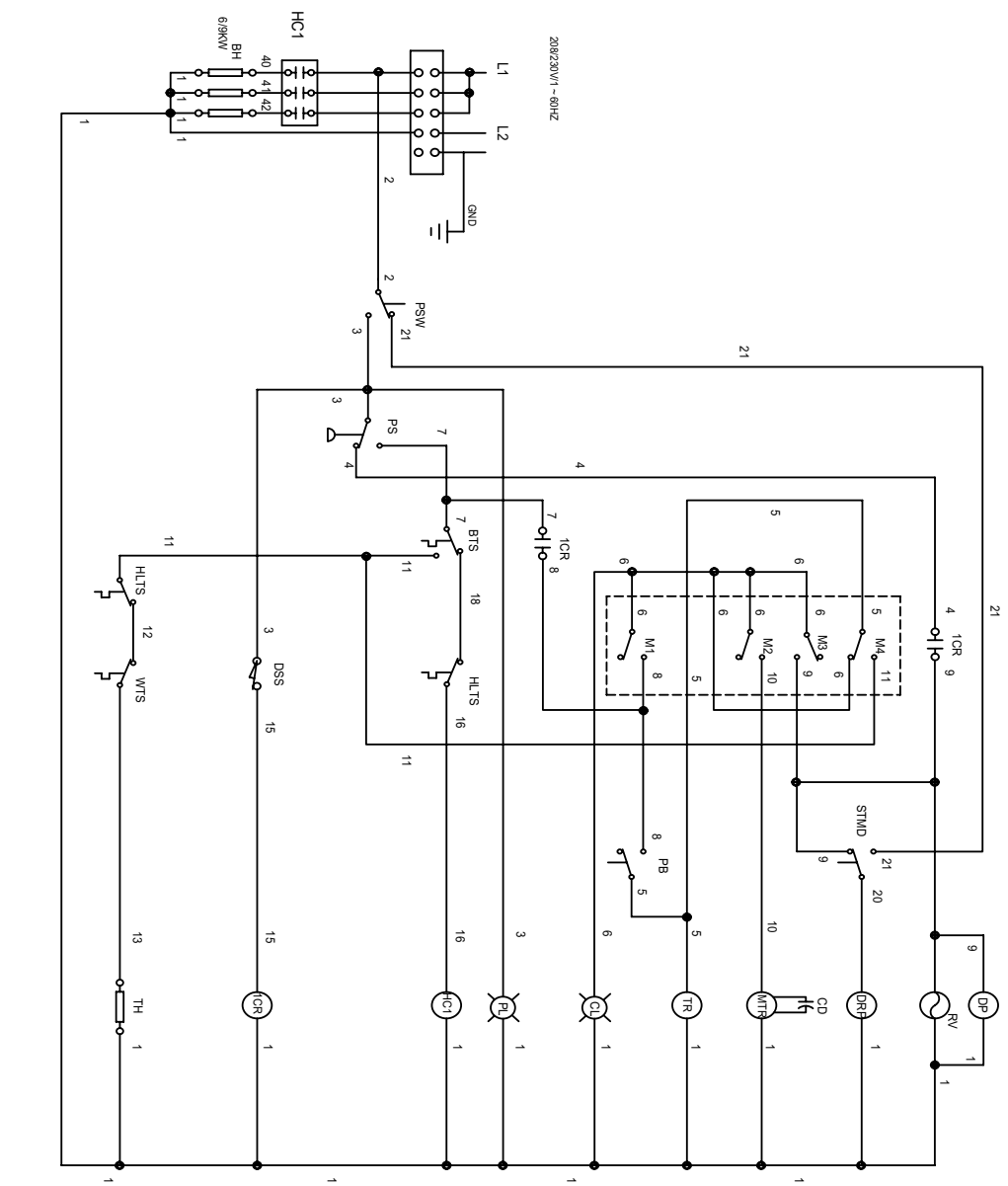

SYMBOL	DESCRIPTION
1CR	AUXILIARY RELAY
BC1	BOOSTER CONTACTOR
BH	BOOSTER HEATER ELEMENT
BTS	BOOSTER THERMOSTAT
CD	CAPACITOR
CL	CYCLE LIGHT
DP	DETERGENT PUMP
DPR	DISCHARGE PUMP
DSS	DOOR CONTACT
HTLS	TANK HIGH LIMIT THERMOSTAT
HTS	BOOSTER SAFETY THERMOSTAT
M1/4	TIMER CONTACTS
MTR	WASH PUMP MOTOR
PB	CYCLE START BUTTON
PL	POWER ON LIGHT
PS	PRESSURE SWITCH
PSW	ON/OFF BUTTON
RV	HOT WATER SOLENOID VALVE
STMD	START MANUAL DRAIN
TH	TANK HEATER ELEMENT
TR	TIMER MOTOR
WTS	TANK THERMOSTAT

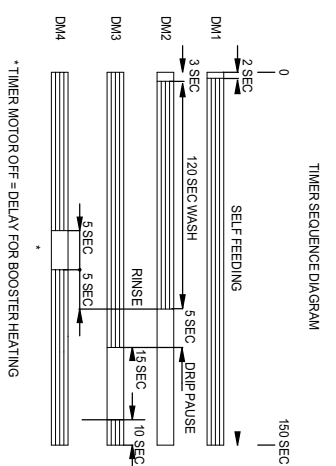

TIMER SEQUENCE DIAGRAM

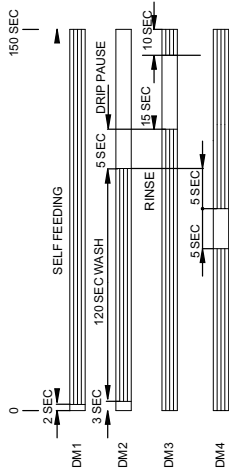

*TIMER MOTOR OFF = DELAY FOR BOOSTER HEATING

SYMBOL	DESCRIPTION
1CR	AUXILIARY RELAY
BC1	BOOSTER CONTACTOR
BH	BOOSTER HEATER ELEMENT
BTS	BOOSTER THERMOSTAT
CD	CAPACITOR
CL	CYCLE LIGHT
DP	DETERGENT PUMP
DRP	DISCHARGE PUMP
DSS	DOOR CONTACT
HTLS	TANK HIGH LIMIT THERMOSTAT
HLTS	BOOSTER SAFETY THERMOSTAT
M1/4	TIMER CONTACTS
MTR	WASH PUMP MOTOR
PB	CYCLE START BUTTON
PL	POWER ON LIGHT
PS	PRESSURE SWITCH
PSW	ON/OFF BUTTON
RV	HOT WATER SOLENOID VALVE
STMD	START MANUAL DRAIN
TH	TANK HEATER ELEMENT
TR	TIMER MOTOR
WTS	TANK THERMOSTAT

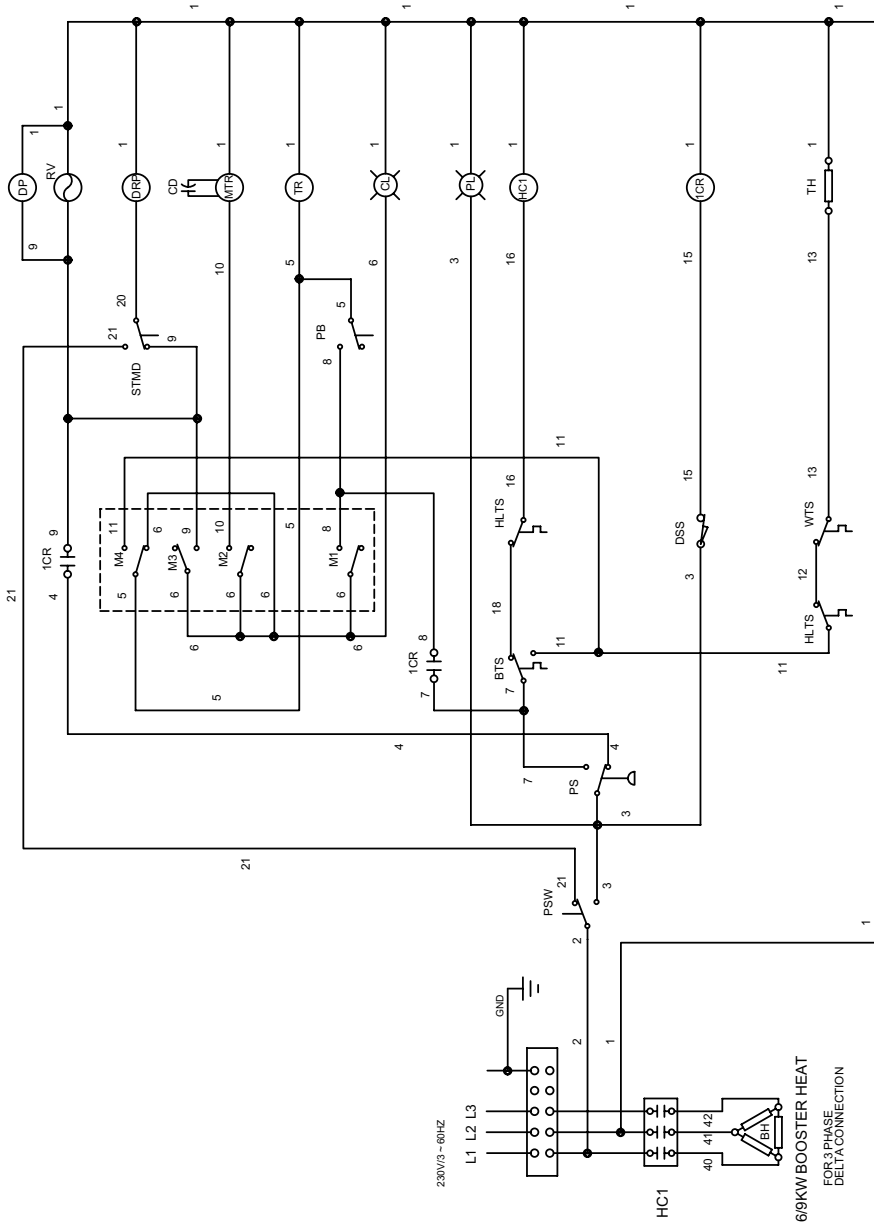

619KW BOOSTER HEAT
FOR 3 PHASE
DELTA CONNECTION

CUSTOMER TO SUPPLY WATER VOLTAGE RANGE AS
ASSIGNED PER ORDER. TO DISCONNECT SWITCH
ALL POWER SUPPLIED TO EACH CONNECTION POINT
MUST COMPLY WITH ALL LOCAL ELECTRIC CODES.
DRAWN BY JMC/ALLISTER SCALE OF 1
DATE 22SEP03 SHEET SH1 OF 1

REV.	DESCRIPTION	DATE	BY

REV.	DESCRIPTION	DATE	BY



SCHEMATIC: 301-HT
THREE PHASE
B 0510727 REV. 0

