



Installation Manual with Service Replacement Parts



**Undercounter
High Temperature
Dishwasher**

Model:

301HT M2

High temperature dishwasher
with built-in electric booster

Dishwasher Serial No.



www.moyerdiebel.com

Issue Date: 1.9.09

Manual P/N 114150 rev. B

Beginning with S/N 61017 and above

P.O. Box 4183
Winston-Salem, NC 27115
336/661-1992 Fax: 336/661-1660
Toll-free: 800/858-4477

2674 N. Service Road, Jordan Station
Ontario, Canada L0R 1S0
905/562-4195 Fax: 905/562-4618
Toll-free: 800/263-5798

Printed in the USA



For future reference, record your dishwasher information in the box below.

Model Number _____ Serial Number _____

Voltage _____ Hertz _____ Phase _____

Moyer Diebel Service Agent _____ Tel: _____

Moyer Diebel Parts Distributor _____ Tel: _____



The data plate with model and serial number is mounted the lower right-side of the machine.

National Service Department



In Canada:
Toll-free: 800/263-5798
Tel: 905/562-4195
Fax: 905/562-4618
email: service@moyerdiebellimited.com



In the USA:
Toll-free: 800/858-4477
Tel: 336/661-1992
Fax: 336/661-1660
email: service@moyerdiebel.com

ATTENTION:

The dishwasher model no., serial no., voltage, Hz and phase are needed to identify your machine and to answer questions.

Please have this information on-hand if you call for service assistance.

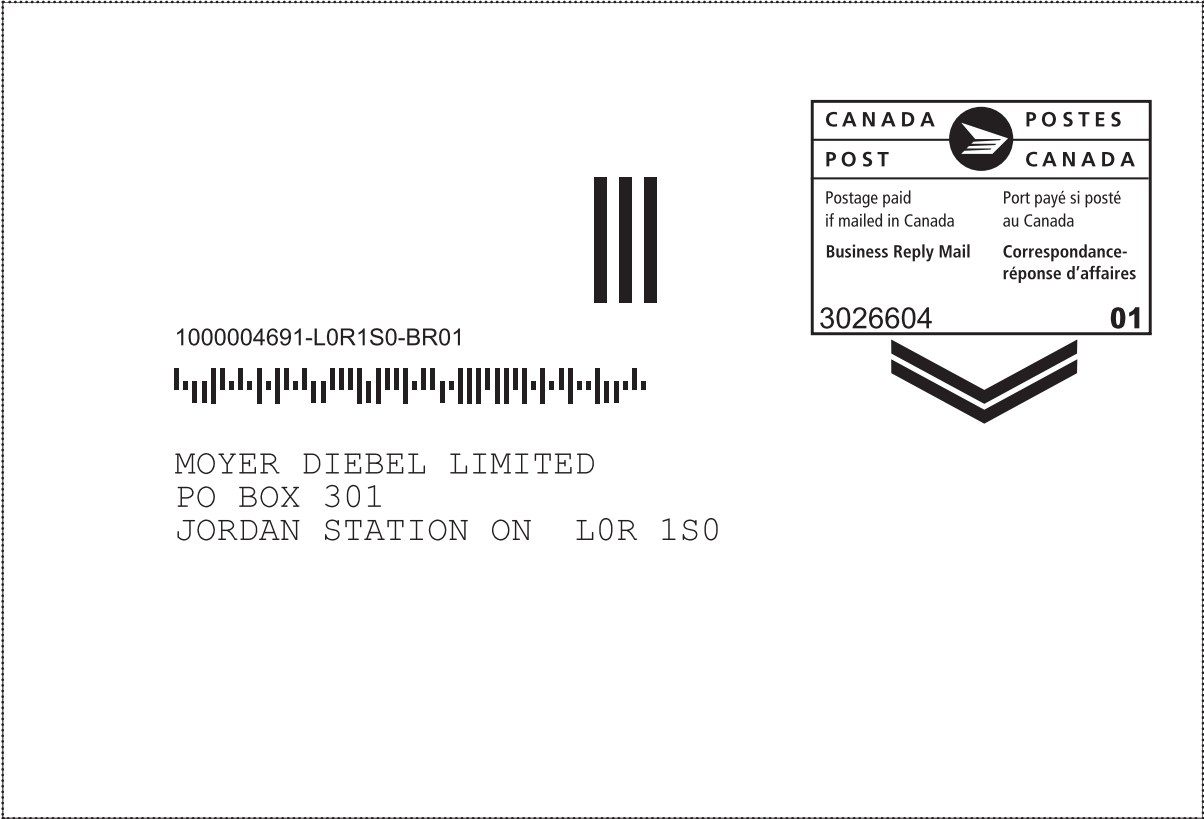

ATTENTION:

Complete the back of the POSTAGE PAID WARRANTY CARD below, then cut along the dashed lines and mail immediately to make sure that your machine warranty is validated. **USE CANADIAN WARRANTY CARD IN CANADA AND USA WARRANTY CARD IN THE UNITED STATES.**

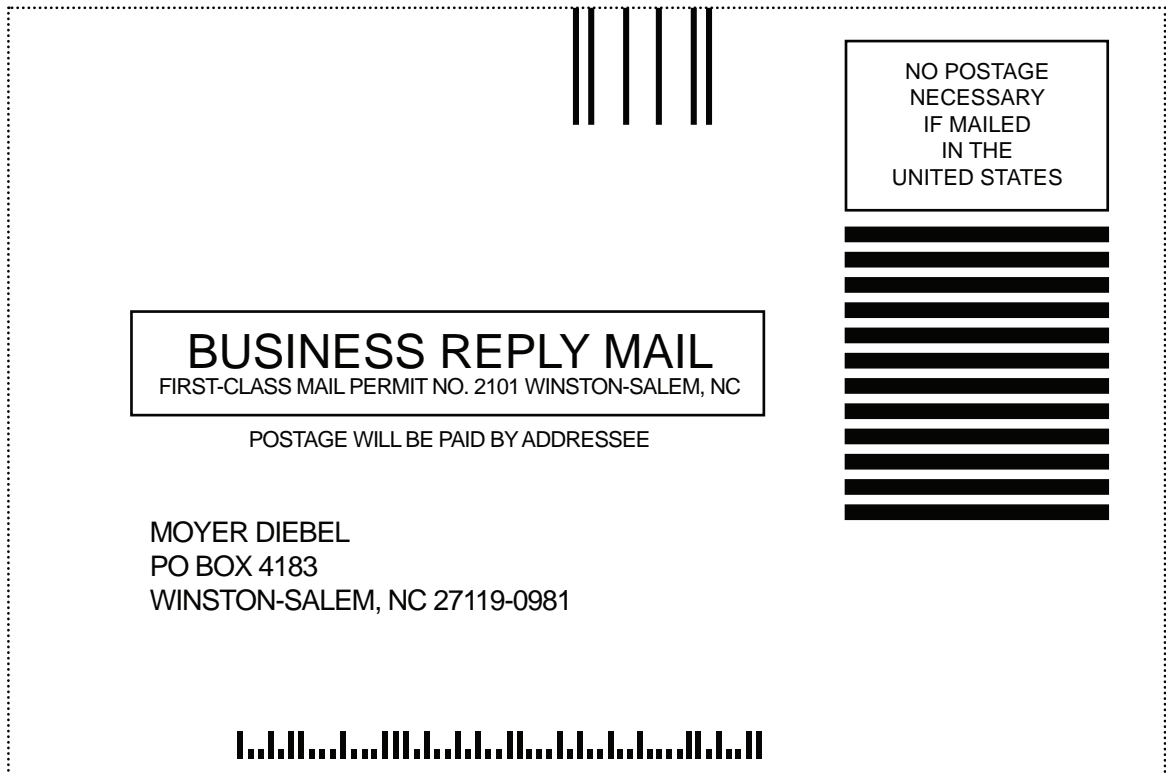

WARRANTY REGISTRATION CARD

Model

Serial #

Date of Installation: ___/___/___

Company Name: _____

Address: _____
(Street) State or Province Zip Code

Telephone #: () _____ --- _____

Contact: _____

Installation Company: _____

Address: _____

Telephone #: _____

Contact: _____

This Card Must Be Returned to Validate Machine Warranty:

IMPORTANT IMPORTANT

WARRANTY REGISTRATION CARD

Model

Serial #

Date of Installation: ___/___/___

Company Name: _____

Address: _____
(Street) State or Province Zip Code

Telephone #: () _____ --- _____

Contact: _____

Installation Company: _____

Address: _____

Telephone #: _____

Contact: _____

This Card Must Be Returned to Validate Machine Warranty:

IMPORTANT IMPORTANT

Revision History

The Revision History can contain part number changes, new instructions, or information that was not available at print time.

We reserve the right to make changes to this manual without notice and without incurring any liability by making the changes.

Equipment owners may request a revised manual, at no charge, by calling 1 (800) 858-4477 in the USA or 1 (800) 263-5798 in Canada.

Revision Date	Revised Pages	Serial Number Effectivity	Revision Description
4.15.06	All	61017	Released 1st edition
6.21.07	23	61017	Revised pump assembly P/N's
1.9.09	All	61017	Updated , added P/N's

Limited Warranty

Moyer Diebel Limited, P.O. Box 4183, Winston-Salem, North Carolina 27115, and P. O. Box 301, 2674 North Service Road, Jordan Station, Ontario, Canada L0R 1S0 warrants machines, and parts, as set out below.

Warranty of Machines: Moyer Diebel Limited warrants all new machines of its manufacture bearing the name "Moyer Diebel" and installed within the United States and Canada to be free from defects in material and workmanship for a period of one (1) year after the date of installation or fifteen (15) months after the date of shipment by Moyer Diebel, whichever occurs first. [See below for special provisions relating to Model Series DF and SW.] The warranty registration card must be returned to Moyer Diebel within ten (10) days after installation. If warranty card is not returned to Moyer Diebel within such period, the warranty will expire after one year from the date of shipment.

Moyer Diebel will not assume any responsibility for extra costs for installation in any area where there are jurisdictional problems with local trades or unions.

If a defect in workmanship or material is found to exist within the warranty period, Moyer Diebel, at its election, will either repair or replace the defective machine or accept return of the machine for full credit; provided, however, as to Model Series DF and SW, Moyer Diebel's obligation with respect to labor associated with any repairs shall end (a) 120 days after shipment, or (b) 90 days after installation, whichever occurs first. In the event that Moyer Diebel elects to repair, the labor and work to be performed in connection with the warranty shall be done during regular working hours by a Moyer Diebel authorized service technician. Defective parts become the property of Moyer Diebel. Use of replacement parts not authorized by Moyer Diebel will relieve Moyer Diebel of all further liability in connection with its warranty. In no event will Moyer Diebel's warranty obligation exceed Moyer Diebel's charge for the machine. The following are not covered by Moyer Diebel's warranty:

- a. Lighting of gas pilots or burners.
- b. Cleaning of gas lines.
- c. Replacement of fuses or resetting of overload breakers.
- d. Adjustment of thermostats.
- e. Adjustment of clutches.
- f. Opening or closing of utility supply valves or switching of electrical supply current.
- g. Adjustments to chemical dispensing equipment.
- h. Cleaning of valves, strainers, screens, nozzles, or spray pipes.
- i. Performance of regular maintenance and cleaning as outlined in operator's guide.
- j. Damages resulting from water conditions, accidents, alterations, improper use, abuse, tampering, improper installation, or failure to follow maintenance and operation procedures.

Examples of the defects not covered by warranty include, but are not limited to: (1) Damage to the exterior or interior finish as a result of the above, (2) Use with utility service other than that designated on the rating plate, (3) Improper connection to utility service, (4) Inadequate or excessive water pressure, (5) Corrosion from chemicals dispensed in excess of recommended concentrations, (6) Failure of electrical components due to connection of chemical dispensing equipment installed by others, (7) Leaks or damage resulting from such leaks caused by the installer, including those at machine table connections or by connection of chemical dispensing equipment installed by others, (8) Failure to comply with local building codes, (9) Damage caused by labor dispute.

Warranty of Parts: Moyer Diebel warrants all new machine parts produced or authorized by Moyer Diebel to be free from defects in material and workmanship for a period of 90 days from date of invoice. If any defect in material and workmanship is found to exist within the warranty period Moyer Diebel will replace the defective part without charge.

DISCLAIMER OF WARRANTIES AND LIMITATIONS OF LIABILITY. MOYER DIEBEL'S WARRANTY IS ONLY TO THE EXTENT REFLECTED ABOVE. MOYER DIEBEL MAKES NO OTHER WARRANTIES, EXPRESS OR IMPLIED, INCLUDING, BUT NOT LIMITED TO, ANY WARRANTY OF MERCHANTABILITY, OR FITNESS OF PURPOSE. CHAMPION/MOYER DIEBEL SHALL NOT BE LIABLE FOR INCIDENTAL OR CONSEQUENTIAL DAMAGES. THE REMEDIES SET OUT ABOVE ARE THE EXCLUSIVE REMEDIES FOR ANY DEFECTS FOUND TO EXIST IN CHAMPION/MOYER DIEBEL DISHWASHING MACHINES AND MOYER DIEBEL PARTS, AND ALL OTHER REMEDIES ARE EXCLUDED, INCLUDING ANY LIABILITY FOR INCIDENTALS OR CONSEQUENTIAL DAMAGES.

Moyer Diebel does not authorize any other person, including persons who deal in Moyer Diebel dishwashing machines, to change this warranty or create any other obligation in connection with Moyer Diebel Dishwashing Machines.

Table of Contents

<i>Revision History</i>	<i>i</i>
<i>Limited Warranty</i>	<i>ii</i>
<i>Model Descriptions</i>	<i>iv</i>
Installation	1
Receiving	1
Electrical Connection	3
Plumbing Connections	4
Chemical Dispensers	5
Initial Start-up	6
Operation	8
Cleaning	19
De-liming	10
Maintenance	11
Troubleshooting	12
Service Replacement Parts	15
Electrical Schematic and Timing Chart	39

Model Descriptions

Model 301HT M2:

High temperature hot water sanitization undercounter dishwasher with a 40°F/22°C rise built-in stainless steel electric booster heater.
Rinse-Sentry to ensure 180°F/82°C final rinse water temperature
Pressure regulating valve (PRV)
Built-in detergent and rinse-aid chemical dispensing pumps
13" door opening clearance
1 flat-bottom dish rack and 1 peg dish rack
1 year parts and labor warranty.

Options:

70°F/39°C rise built-in stainless steel electric booster heater
CST- Combination sink/table (*Machine on right-side of table*)
CST- Combination sink/table (*Machine on left-side*)
6" floor stand
17RS- 17" floor stand
Three phase operation
Additional flat-bottom and peg dish racks

Receiving

1. Check the corrugated box that protected the dishwasher during shipment for punched holes or impact marks.
2. Inspect the shipping pallet for splintered or broken boards.
3. Inspect the exterior of the dishwasher while still mounted on the pallet for signs of damage.
4. If no damage is found, proceed with lifting the dishwasher from its pallet. Be careful to lift the dishwasher by the main frame if using a forklift.
5. Make sure the four legs are screwed firmly in place after landing the machine.
6. Check the packing list to ensure all accessories are with the dishwasher.
7. Complete the warranty card located at the front of this manual and mail at once in order to validate your warranty.
8. Move the dishwasher close to its permanent location.
9. Remove the protective covering from the dishwasher and identify the utility connections. Information cards and stickers must not be removed from the dishwasher until the installation is complete.

Receiving

Care should be taken when lifting the machine to prevent damage.

The machine is normally shipped on a skid enclosed by straps. When transporting the machine, use a lift truck or fork lift, positioning the box properly on the forks.

1. Immediately after unpacking your machine, inspect for any shipping damages. If damage is found, save the packing material and contact the carrier immediately.
2. Remove the dishwasher from the skid. Adjust the feet if required, then move the machine to its permanent location.
3. Level the machine (if required) by placing a level on the top of the machine and adjusting the feet. Level the machine front-to-back and side-to-side.
4. Remove any foreign material from inside of the machine.

Note:

Installers must follow applicable sanitation, safety, plumbing, and electrical codes and regulations; and work in accordance with best practices for dishwasher installation.

Electrical Connections

Note:

Leave enough electrical cable behind the machine so that the dishwasher can be pulled forward a minimum of two feet to be serviced.

Warning:

Electrical and grounding connections must comply with all local electrical codes or in the absence of local codes then connections must comply with the National Electrical Code.

Warning: When working on the dishwasher, disconnect the main electric service and tag it to indicate work is being done on that circuit.

1. The electrician should compare the electrical specifications on the machine electrical data plate (located in the control panel) to the electrical power supply before connecting the machine to the incoming service at a fused disconnect switch.

IMPORTANT: The 208-240V/60Hz/1PH electrical supply service for this machine must be a 2-wire plus ground service. For optional 208-240V/60Hz/3PH the electrical supply service must be a 3-wire plus ground service.

2. On the 208V-240V models, a knockout is provided at the rear of the junction box for electrical service connections. A fused disconnect switch or circuit breaker (supplied by user) is required to protect each power supply circuit.

Refer to the **MACHINE ELECTRICAL CONNECTION DATA PLATE** for the dishwasher power requirements.

Plumbing Connections

Water Connections

1. Connect the hot water supply to the fill hose provided with a 3/4" NPT fitting.
2. Install a manual shut-off valve in the water supply line to accommodate servicing the machine. The shut-off valve should be the same size or larger than the supply line and installed as close to the dishwasher as possible.
3. Install a 3/4" pressure reducing valve (PRV) (supplied with machine) in the water supply line, and set at 20-22 PSI/138-151kPa. Install the PRV downstream from the service shut-off valve and as close to the dishwasher as possible.

Drain Connections

1. Drain hose must be supported by bracket provided (shipped inside of machine).
2. The drain hose bracket must be mounted a minimum of 2 feet above the finished drain, either on the rear of the machine or on the wall.
3. The maximum height of the drain from the floor must not exceed 3 feet.
4. Connect the 3/4" I.D. flexible drain hose to a 1-1/2" wye (Y) drain fitting. Use a 3/4" hose

Note:

Plumbing connections must comply with local health and plumbing codes.

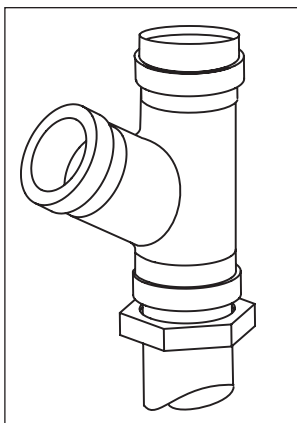

Connect machine flexible drain hose to a wye fitting.

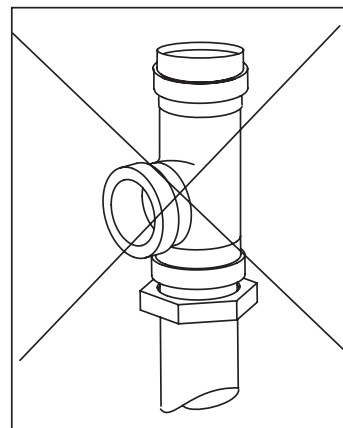

Do not connect the machine flexible drain hose to a 90° fitting.

Chemical Dispensers

ATTENTION:

Chemical dispensers must be electrically grounded in compliance with applicable electric codes.

adapter (supplied by others). Do not connect drain hose to a 90° drain fitting.

Detergent

The machine is equipped with an automatic detergent dispensing pump system.

1. Use a qualified detergent/chemical supplier for your detergent.
2. Your machine is supplied with a detergent dispensing pump that is internally wired and ready for use. Use a commercial grade liquid detergent and insert the red pickup tube into the detergent container. The pickup tube has a strainer on the end to prevent the crystallized chemical from clogging the supply lines.

Always wash hands under running water if they come into contact with the detergent and comply with the instructions pertaining to the specific type of detergent.

To prime the peristaltic pump:

1. Insert pick-up tube into the detergent container.
2. Close machine door and switch machine on.
3. Push and hold the prime switch.

Rinse Aid

1. Use a qualified/chemical supplier for your rinse aid needs.
2. Insert the transparent tube into the container containing the rinsing agent.
3. Push and hold the prime switch

Completing the Installation

1. Remove any foreign materials from inside the machine.
2. Install the scrap screens, wash and rinse arms, strainer basket and overflow tube.
3. After plumbing and electrical connections are completed, check machine for water leaks by closing the door, then depressing the **ON** switch. This allows the tank to begin filling and to reach temperature.
4. Open the door and check the water level. The water level should be 2 inches above the scrap screen.
5. Close the door fully.

Caution:

Connecting chemical dispensers at points other than those recommended by the factory may damage the dishwasher electrical system. Damage caused by the installation of chemical equipment will not be covered the WARRANTY.

Initial Start Up

1. The built-in stainless steel electric booster **was shipped without water.**
2. A manila card located above the power switch explains how to turn the machine on for the first time.

Initial Start-up:

1. Check the placement of the dishwasher:
Compare the machine location with the building plan.
2. Check that all options and/or accessories are installed.
3. Remove protective white wrapping, tape, and other packing materials and discard.
4. Remove any foreign materials from the interior of the machine.



Initial Start Up

The following is a summary of your model 301HT dishwasher operating cycle:

1. The door must be closed to begin the cycle.
2. Press the **POWER** button to fill the wash tank.
3. The booster heater comes on when the correct water level has been reached.
4. Press and hold the **START** button to start the cycle. NOTE : After pushing the start button the first cycle of each day could take at least 15-20 minutes if the machine was not allowed to warm up first.
5. The pump runs during the wash cycle for approximately 120 seconds. **The wash cycle duration is extended if the booster water temperature does not reach 180°F/82°C.**
6. After a 5 second pause, the fill valve opens and the rinse cycle starts.
7. The machine rinses for 15 seconds. The cycle light turns off indicating that the cycle is complete. **DO NOT** open the door until the cycle light turns off.
8. Open the door and remove the rack of clean ware.



Operation

Operation Procedures

1. Check that the spray arms, overflow tube and scrap screens are in place.
2. Close the door. Press the **POWER** switch. The tank will begin to fill with water.
This procedure is only needed when the tank is empty.
3. When the tank is full, check the wash tank temperature gauge. Minimum wash temperature is **150°F/66°C**.
4. Scrap and preflush all items to be washed, load items into rack. Wash only one layer of silverware in a rack at a time.

Note: **DO NOT OVERLOAD** the rack.

5. Open the door and insert the rack of wares into the machine.
6. Close the door. Press the **START** switch and hold for 1 second, then release. This will start the wash cycle. The light illuminates.

Note: The machine may be stopped at any time during the cycle by opening the door. Closing the door resumes the cycle where it was stopped.

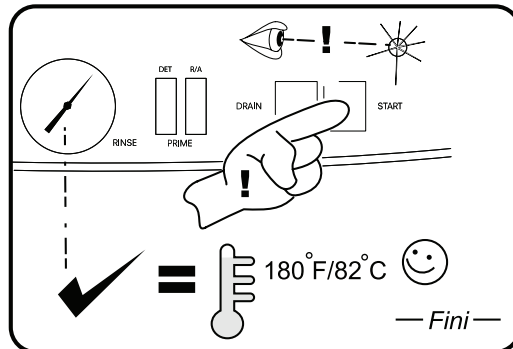
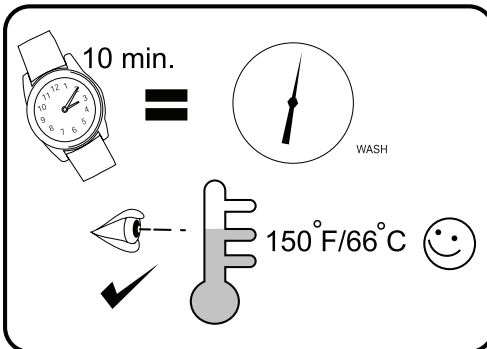
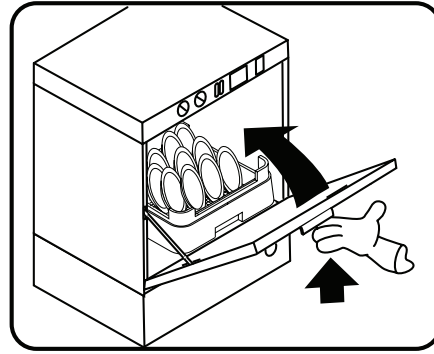
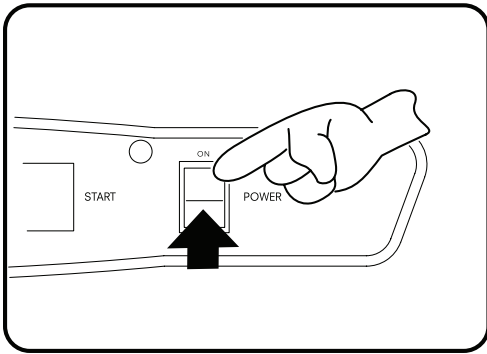

Cleaning

After Meal Periods or 8 Hours of Operation

1. Press power switch **OFF**
2. Remove the overflow tube and press and hold the **DRAIN** switch to drain the machine.
3. Wipe the interior to remove any debris.
4. Clean the screens after every meal period and more frequently during heavy usage. Do not allow screens to become clogged with debris.
5. Inspect wash and rinse arms. Clean if necessary.
6. Replace overflow tube.
7. Close door.
8. Press the **POWER** button to refill machine.

Weekly

1. Check the dishwasher installation site and clean if necessary.
2. Inspect the area behind the dishwasher and clean as required.
3. Inspect the chemical supply containers for spills and clean.

De-liming

Danger:

Death or serious injury may result when de-liming solution is mixed with sodium hypochlorite (*chlorine bleach*) sanitizing agent. Mixing may cause hazardous gases to form.

De-liming solution and other acids must never be mixed with chlorine, iodine, bromine, or fluorine.

Caution:

Skin contact with de-liming solutions can cause severe irritation and possible chemical burns. Always wear protective clothing when handling chemicals.

Attention:

Contact your chemical supplier for specific safety procedures and instructions for the use of the de-liming solution supplied for the dishwasher.

De-liming solution or other chemicals are not supplied by the dishwasher manufacturer.

De-liming Procedure

1. Remove the chemical pick-up tubes from their supply containers.
2. Place the pick-up tubes in a container of warm water.
3. Push each prime switch to flush remaining chemicals out of the chemical tubing.
3. Close the door fully.
4. Press the **POWER** switch to fill the machine.
5. Open the door and add de-liming chemical into the wash tank compartment.
6. Close the door fully, then press the **START** switch to begin a cycle.
7. Run 3 complete cycles, then press the **POWER** switch to the OFF position.
8. Open the door and remove the drain/overflow tube from the wash tank.
9. Close the door.
10. Press and Hold the **DRAIN** switch to drain the machine.
11. Replace the drain/overflow tube, then close the door.
12. Re-insert the chemical pick-up tubes in the proper containers and prime the chemical dispensing pumps.
13. De-liming is complete.

Maintenance

Daily Maintenance

1. Keep your dishwasher and the surrounding area clean.
2. Immediately report loose, broken or missing parts to your supervisor.
3. Check drains for flow restrictions.
4. Check the dishwasher for leaks.
5. Operate the dishwasher as explained in this manual.

Monthly Maintenance

1. Inspect pump hoses, door linkage, springs, and exterior of dishwasher for wear.
2. Inspect the wash arm bearings and O-rings.
3. Check the condition of scrap screens, and dish racks for bent or broken pieces.
4. Check the toggle switches and indicator lights for damage.
5. Check the wash pump motor for loud bearings and leaking pump seal.

Annual Maintenance

Call your authorized service agent or local service representative and schedule a complete inspection of your dishwasher by a trained professional.

Troubleshooting

In order to find the cause of a breakdown or abnormal operating condition in your dishwasher please ensure that:

1. All power switches are ON.
2. Drain overflow tube is in place and seated.
3. Wash spray arm nozzles and rinse nozzles are clean.
4. Spray arms are in their proper positions.
5. Pump intake and wash tank screens are clean and properly positioned.
6. Detergent and rinse-aid dispensers are adequately filled.
7. Door is fully closed.

Refer to the Troubleshooting Guide below before contacting an authorized service agent for repair.

Condition	Cause	Solution
Cycle keeps running and does not finish	Cold machine	First cycle of the day could take 20 minutes if machine did not warm up.
Machine will not start	Main switch disconnected	Turn on switch.
	Door not closed	Make sure doors are fully closed.
	Door safety switch faulty	Contact your service agency.
	Start switch faulty	Contact your service agency.
Low or no water	Main water supply is turned off. . .	Turn on house water supply.
	Drain/overflow tube is not in place and seated	Place and seat drain/overflow tube.
	Machine doors not fully closed. . .	Close doors securely.
	Faulty fill valve	Contact your service agency.
Continuous filling	Fill valve will not close	Contact your service agency.
	Drain/overflow tube not in place. .	Install drain/overflow tube in tank.
	Air trap lost pressure	Drain machine, reinsert drain/overflow. and refill machine.
Motor not running	Defective motor	Contact your service agency.
Wash water temp to low when in use	Incoming water temp low.	Raise temperature to 140°F/40°C for 40°F/22°C rise booster heater. Raise temperature to 110°F/39°C for 70°F/39°C rise booster heater.
	Defective thermometer.	Check or replace.
	Defective thermostat	Check for proper setting or replace.
	Defective heater element	Check or replace.

Troubleshooting

Condition	Cause	Solution
Insufficient pumped spray pressure	Clogged pump intake screen.	Clean
	Clogged spray pipe	Clean
	Scrap screen full.	Must be kept clean and in place
	Low water level in tank.	Check drain and overflow tube
	Defective pump seal.	Contact service agent
Insufficient final rinse or no final rinse	Clogged rinse nozzle and/or arm. .	Clean with paper clip/delime
	Clogged strainer.	Clean or replace
Low final rinse temperature	Low incoming water	Check the booster be sure the thermostat is set to maintain 180°F/82°C temperature. Check fill valve operation.
	Defective thermometer.	Check for proper setting or replace
Poor washing results	Detergent dispenser not operating properly	Contact detergent supplier
	Insufficient detergents	Contact detergent supplier
	Food Soil concentration too high in wash tank	Drain tank, clean and refill every 2 hours of operation or after each meal period.
	Wash water temperature too low. .	See condition "Wash Tank Water Temperature" above
	Wash arm clogged	Clean
	Wash arm not rotating	Clean arm. Check bearing, replace if necessary.
	Improperly scrapped dishes.	Check scrapping procedures
	Ware improperly placed in rack . . .	Use proper racks. Do not overload racks
	Improperly cleaned equipment . . .	Unclog wash sprays and rinse nozzles to maintain proper pressure and flow conditions. Overflows must be open. Keep wash water as clean as possible.
	Heating element has soil/lime buildup	Clean and/or de-lime.
	Detergent pick up tube in incorrect container	Place RED pick up tube in detergent container

***This Page
Intentionally
Left Blank***

Service Replacement Parts

Illustrations	Page
<i>Hood and Tank Assembly</i>	16
<i>Door Assembly</i>	18
<i>Wash Tank Heater and Chemical Dispensers</i>	20
<i>Fill Piping Assembly</i>	22
<i>Drain Assembly</i>	24
<i>Wash and Rinse Piping Assembly</i>	26
<i>Wash and Rinse Arm Assemblies</i>	28
<i>Wash Pump/Motor Assembly</i>	30
<i>Booster Heater Assembly</i>	32
<i>Control Panel Assembly</i>	34
<i>Control Cabinet Assembly</i>	36

Hood and Tank Assembly

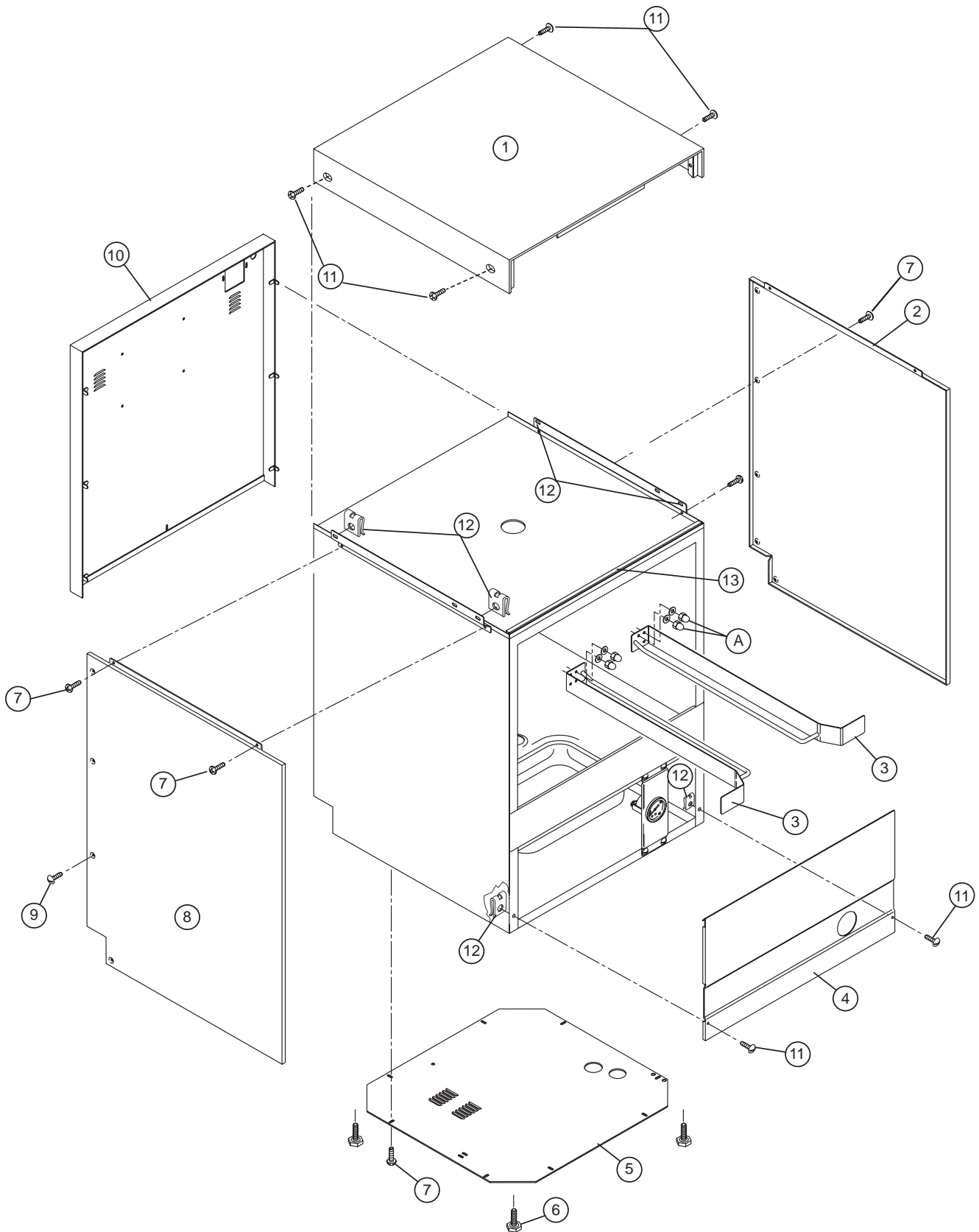

Item No.	Part No.	Description	Qty.	Unit
1	H36145	Panel, Control Cabinet	1	ea
2	H36147	Panel, Side RH	1	ea
3	H35551	Tracks, Rack	2	ea
4	H36151	Panel, Front	1	ea
5	H33576	Bottom Panel	1	ea
6	H25209	Foot, Adjustable	4	ea
7	H25697	Self-Tapping Screw 9 x 13	12	ea
8	H36146	Panel, Side LH	1	ea
9	H25693	Self-Tapping Screw Bevel 2 x 13	4	ea
10	H36148	Panel, Back	1	ea
11	H36728	Screw TS M5 x 20	6	ea
12	H450821	Spring Clip Fastener 5MA	8	ea
13	H36353	Gasket, Top	1	ea
A		HARDWARE FOR TRACKS (Quantities per track)		
	H25744	Washer	2	ea
	H25774	Nut. 5MM	2	ea

Door Assembly

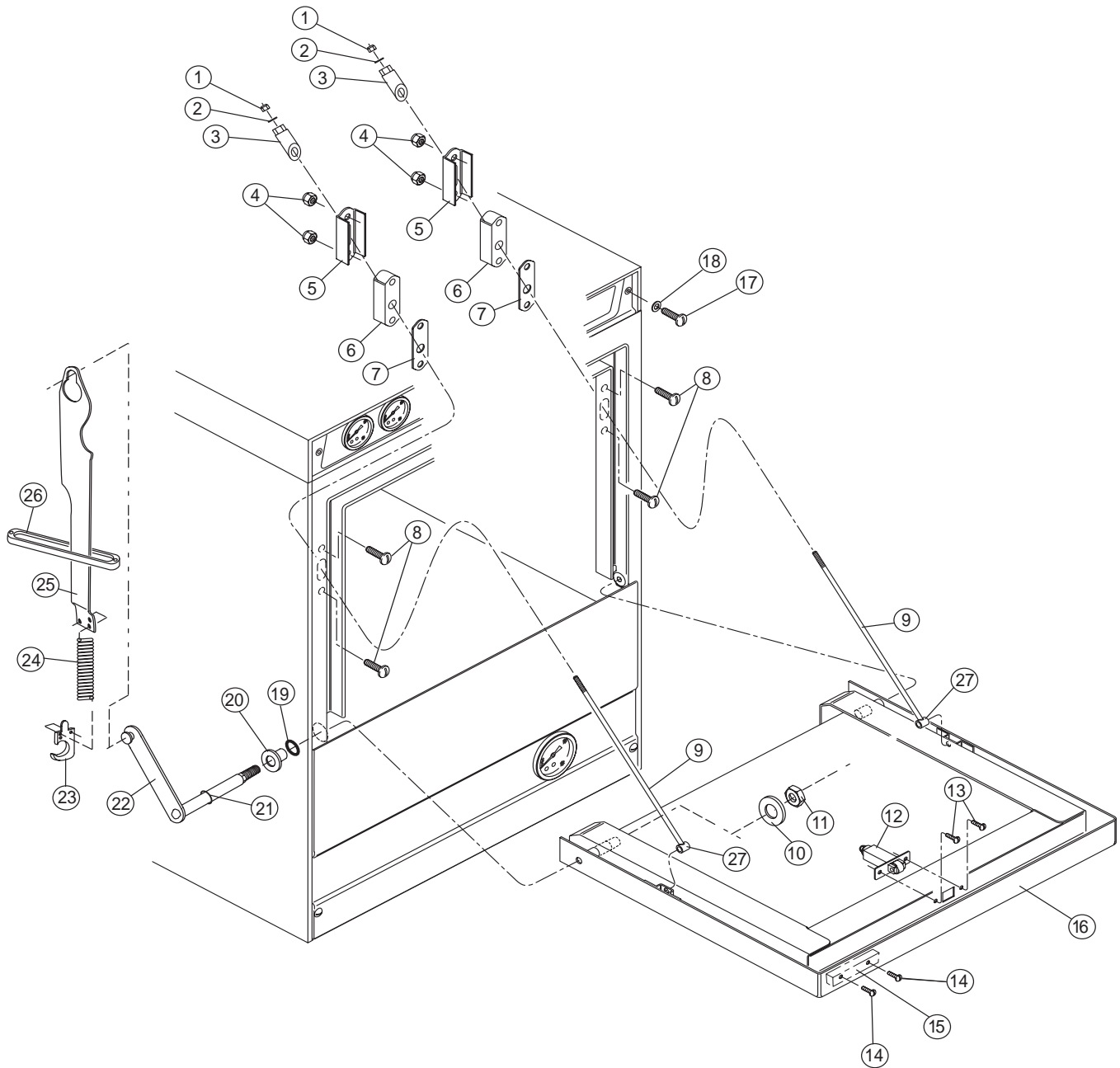

<i>Item No.</i>	<i>Part No.</i>	<i>Description</i>	<i>Qty.</i>	<i>Unit</i>
1	H25791	Nut Plain	2	ea
2	106486	Washer	2	ea
3	107623	Nut Door Support	2	ea
4	H30194	Nut	4	ea
5	H37104	Door Rod Plate Support	2	ea
6	H160909	Door Rod Plate	2	ea
7	H160837	Gasket	2	ea
8	H33387	Screw	4	ea
9	H34144	Door Rod	2	ea
10	H25746	Washer	2	ea
11	H25792	Nut	2	ea
12	H33336	Door Catch	1	ea
13	H25693	Self-Tapping Screw	2	ea
14	H33277	Self-Tapping Screw	2	ea
15	H32969	Door Magnet	1	ea
16	H37162	Door Weldment <i>(Does not include hardware)</i>	1	ea
17	H260223	Screw	2	ea
18	H35171	Washer	2	ea
19	H30473	O-ring	2	ea
20	H37121	Hub	2	ea
21	H34360	O-ring	2	ea
22	H37124	Left Counter Balance Lever	1	ea
—	H37123	Right Counter Balance Lever <i>(Not shown)</i>	1	ea
23	H37170	Spring Hook	2	ea
24	H37171	Door Spring	2	ea
25	H37120	Left Counter Balance Rod	1	ea
—	H37119	Right Counter Balance Rod	1	ea
26	H37122	Guide	2	ea
27	H36174	Door Rod Bushing	2	ea

Wash Tank Heater and Chemical Dispensers

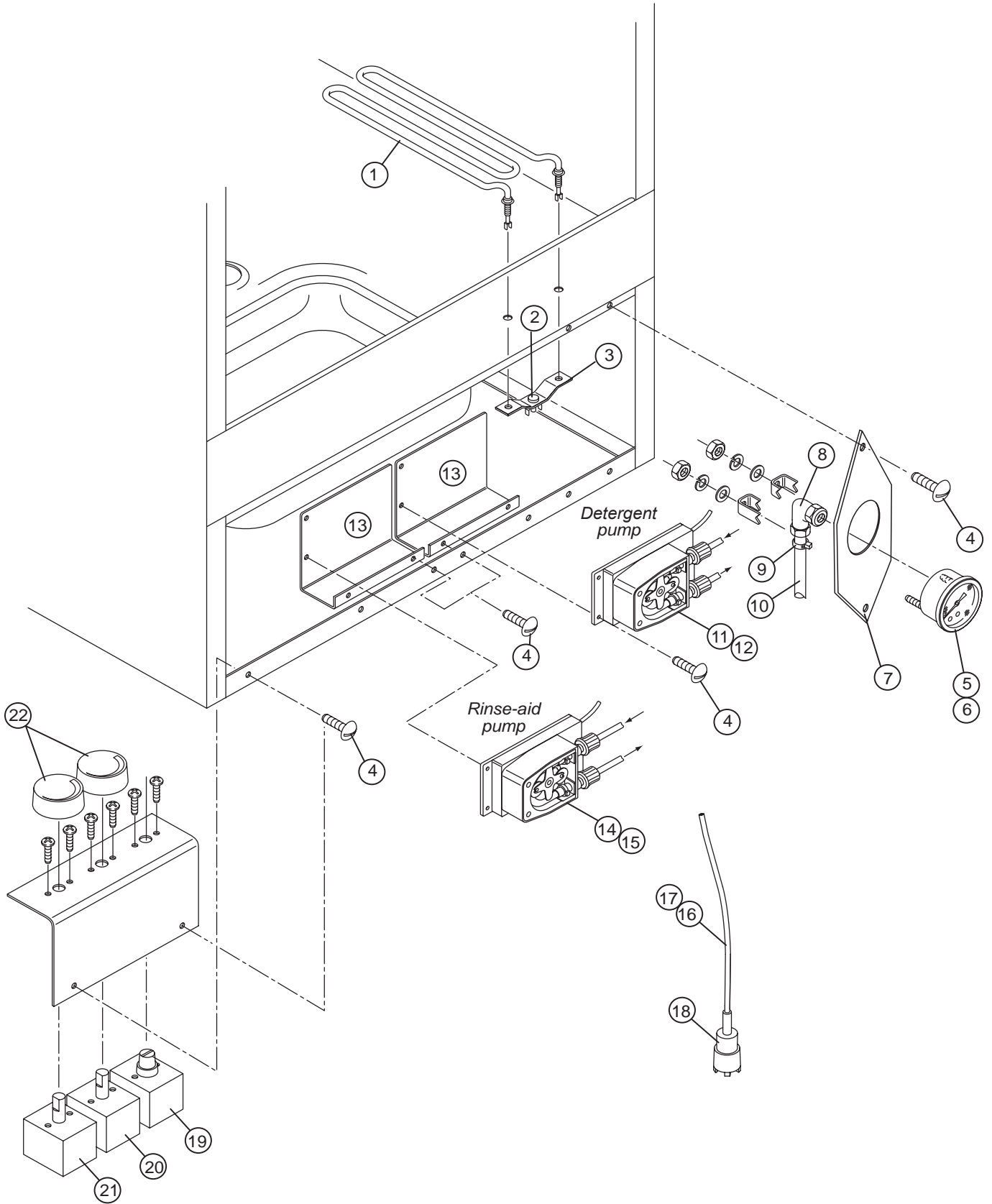

Item No.	Part No.	Description	Qty.	Unit
1	H35162	Wash Tank Heater 2000W 230V	1	ea
2	113604	Wash Tank High Limit Thermostat	1	ea
3	H36351	Support Plate, for Wash Tank High Limit	1	ea
4	H34982	Screw M5 X 12 Half Round Head	14	ea
5	H441402	Pressure Gauge	1	ea
6	H460344	Plate, Adhesive	1	ea
7	H36154	Bracket, Pressure Gauge	1	ea
8	111100	Elbow, 1/4" OD x 1/8" MPT 90° Plastic	1	ea
9	0502563	Clamp, Hose	1	ea
10	107928	1/4" Natural Tubing	A/R	ft.
11	H34358	Peristaltic Pump, Detergent	1	ea
12	H35137	Squeeze Tube, Detergent <i>(comes with black fittings)</i>	1	ea
13	H36271	Bracket, Peristaltic Pump	2	ea
14	H37110	Peristaltic Pump, Rinse-aid	1	ea
15	H37296	Squeeze Tube, Rinse <i>(comes with black fittings)</i>	1	ea
16	0512475	Supply Tubing, Detergent <i>(comes in 13 ft. roll)</i>	1	ea
17	H00166	Supply Tubing, Rinse-aid	A/R	ft.
18	H180726	Strainer, Supply Tubing	2	ea
19	H33745	Hi Limit Thermostat	1	ea
20	H36397	Thermostat, Adjustable, Rinse, 86-203°F/30-95°C	1	ea
21	H25417	Thermostat, Adjustable, Wash, 86-194°F/30-90°C	1	ea
22	H25092	Knob, Thermostat	2	ea

Fill Piping Assembly

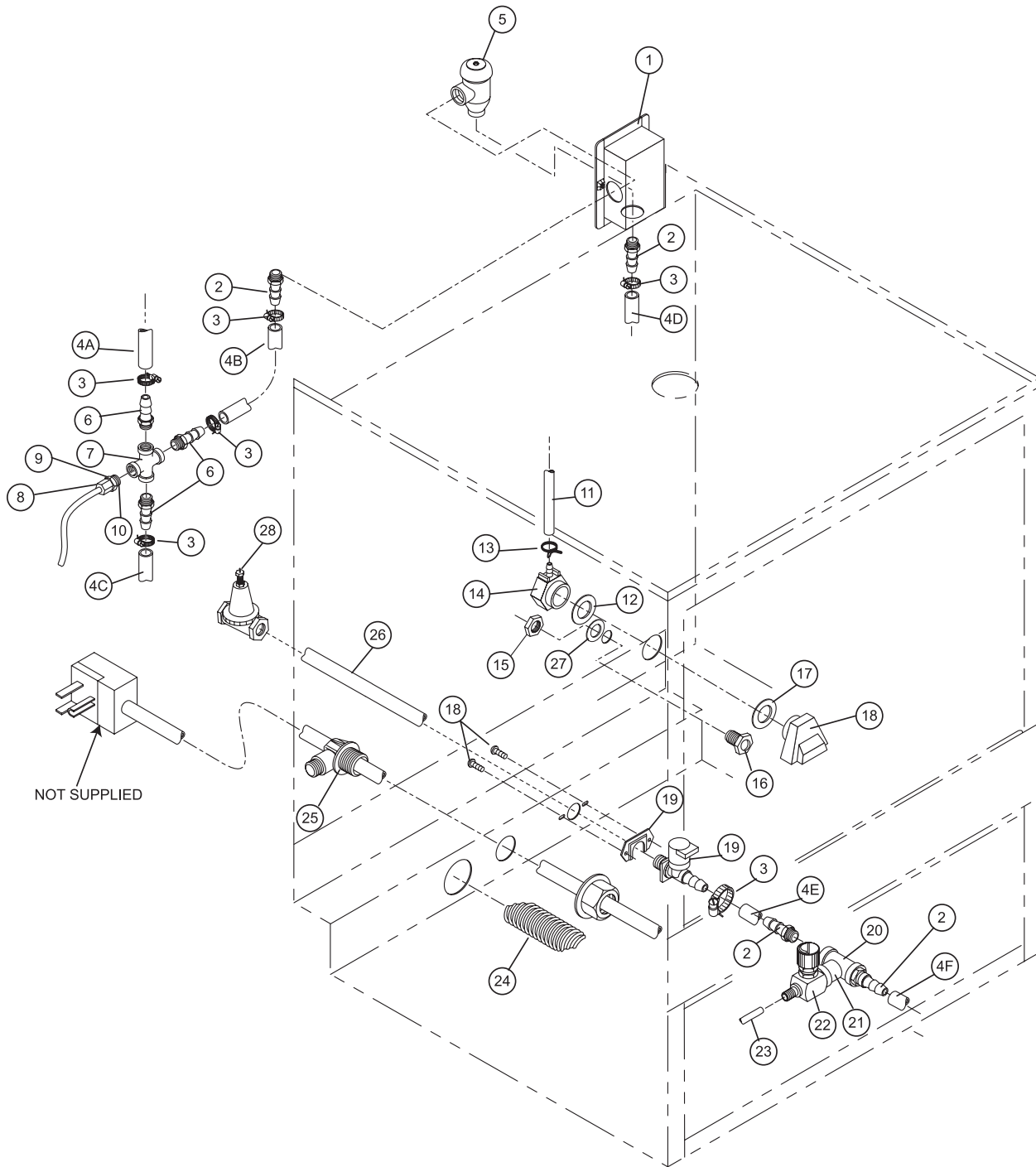

<i>Item No.</i>	<i>Part No.</i>	<i>Description</i>	<i>Qty.</i>	<i>Unit</i>
1	H36156	Vacuum Breaker Mounting Box	1	ea
2	0502651	Hose Barb	4	ea
3	0503679	Clamp, Hose	A/R	
4	H00182	Hose, Blue	A/R	
		A 23-5/8" [600mm]		
		B 15-3/4" [400mm]		
		C 8-1/16" [205mm]		
		D 36-1/4" [920mm]		
		E 8-3/16" [201mm]		
		F 8-1/16" [205mm]		
5	100500	Vacuum Breaker 1/2" NPT	1	ea
–	900836	Repair* Kit 1/2" Vacuum Breaker	A/R	
6	0502651	Hose Barb	3	ea
7	H36173	Cross Tee	1	ea
8	H36289	Right for Brass Insert	1	ea
9	H36607	Brass Insert	1	ea
10	H36290	Raccord, Brass Insert	1	ea
11	H160121	Hose Black	A/R	
12	H25239	Gasket	1	ea
13	H34733	Clamp	1	ea
14	H25011	Cover for Air Trap	1	ea
15	H25778	Nut, Injector	1	ea
16	H18472	Detergent Injector	1	ea
17	H25263	Flat Gasket	1	ea
18	H25010	Air Trap	1	ea
19	H26629	Solenoid Valve 3/4"	1	ea
20	H36172	TEE, 1/2" x 1/2" x 1/8"	1	ea
21	H36349	Brass Reduction	1	ea
22	H280607	Valve	1	ea
23	H160117	Poly Tube	A/R	
24	H36032	Drain Hose	1	ea
25	H33344	Cable Clip	1	ea
26	H34996	Inlet Tube	1	ea
27	H200415	O-ring, Gasket	1	ea
28	107550	Valve Press Reducing 3/4"	1	ea

Drain Assembly

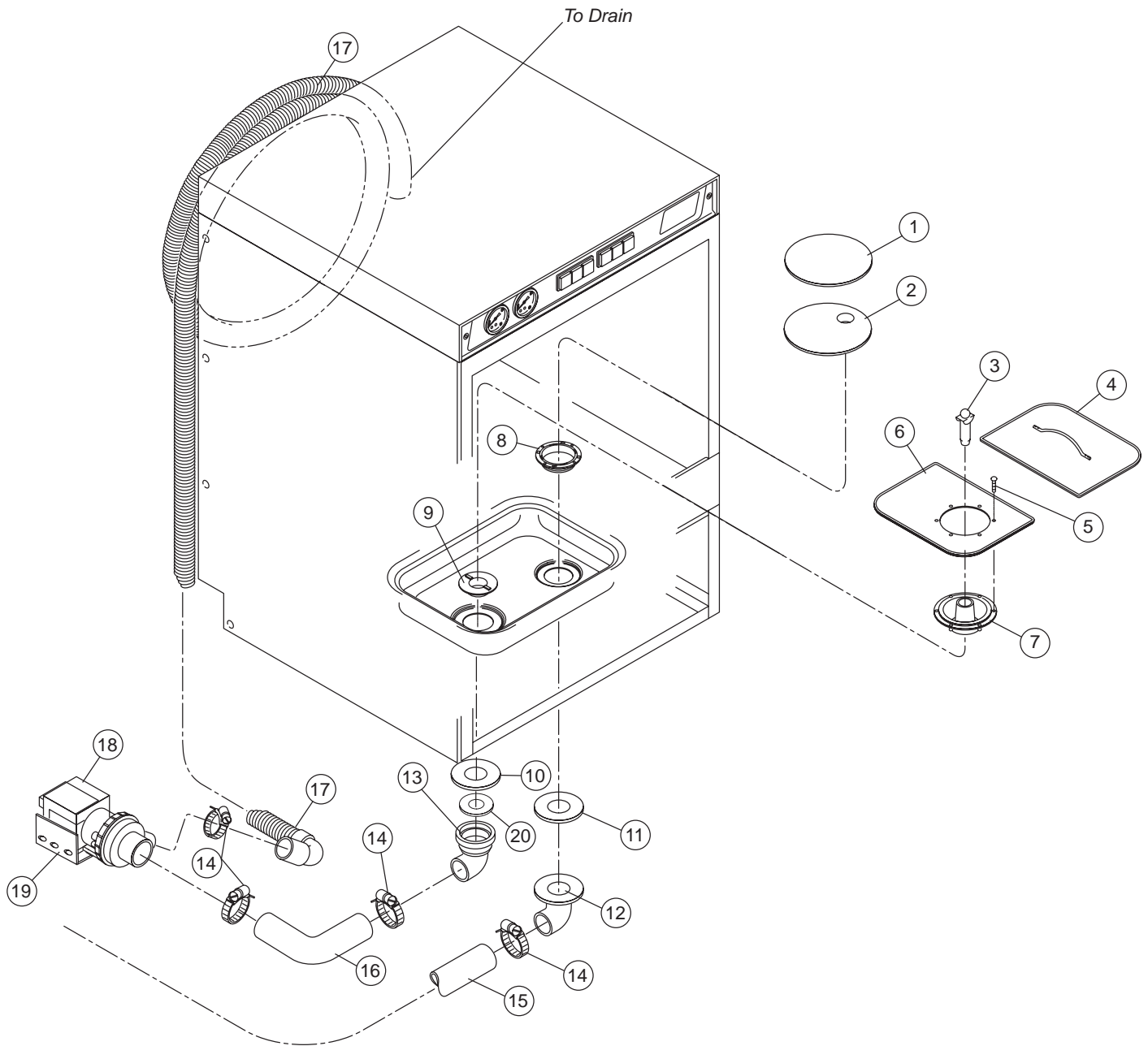

<i>Item No.</i>	<i>Part No.</i>	<i>Description</i>	<i>Qty.</i>	<i>Unit</i>
1	H32796	Cover, Round Filter	1	ea
2	H32795	Bottom, Round Filter	1	ea
3	H36160	Overflow Tube, Drain Pump	1	ea
4	H35895	Scrap Screen	1	ea
5	H25684	Self-Tapping Screw 9mm x 9mm	6	ea
6	H35896	Sump Cover	1	ea
7	H32719	Rubber Sump	1	ea
8	H25006	Nut, Drain Suction	1	ea
9	H34790	Drain Elbow Series	1	ea
10	H26637	Flat Gasket Drain	1	ea
11	H31423	Flat Gasket Suction	1	ea
12	H32715	90° Suction Elbow	1	ea
13	H30421	Drain Fitting Long	1	ea
14	0502563	Clamp, Hose	4	ea
15	H32894	Suction Hose	1	ea
16	H32801	Suction Sleeve, Drain Pump	1	ea
17	H36032	Drain Hose	1	ea
18	H35544	Drain Pump	1	ea
19	H35359	Bracket, Drain Pump	1	ea
20	H28226	O-ring, Gasket	1	ea

Wash and Rinse Piping Assembly

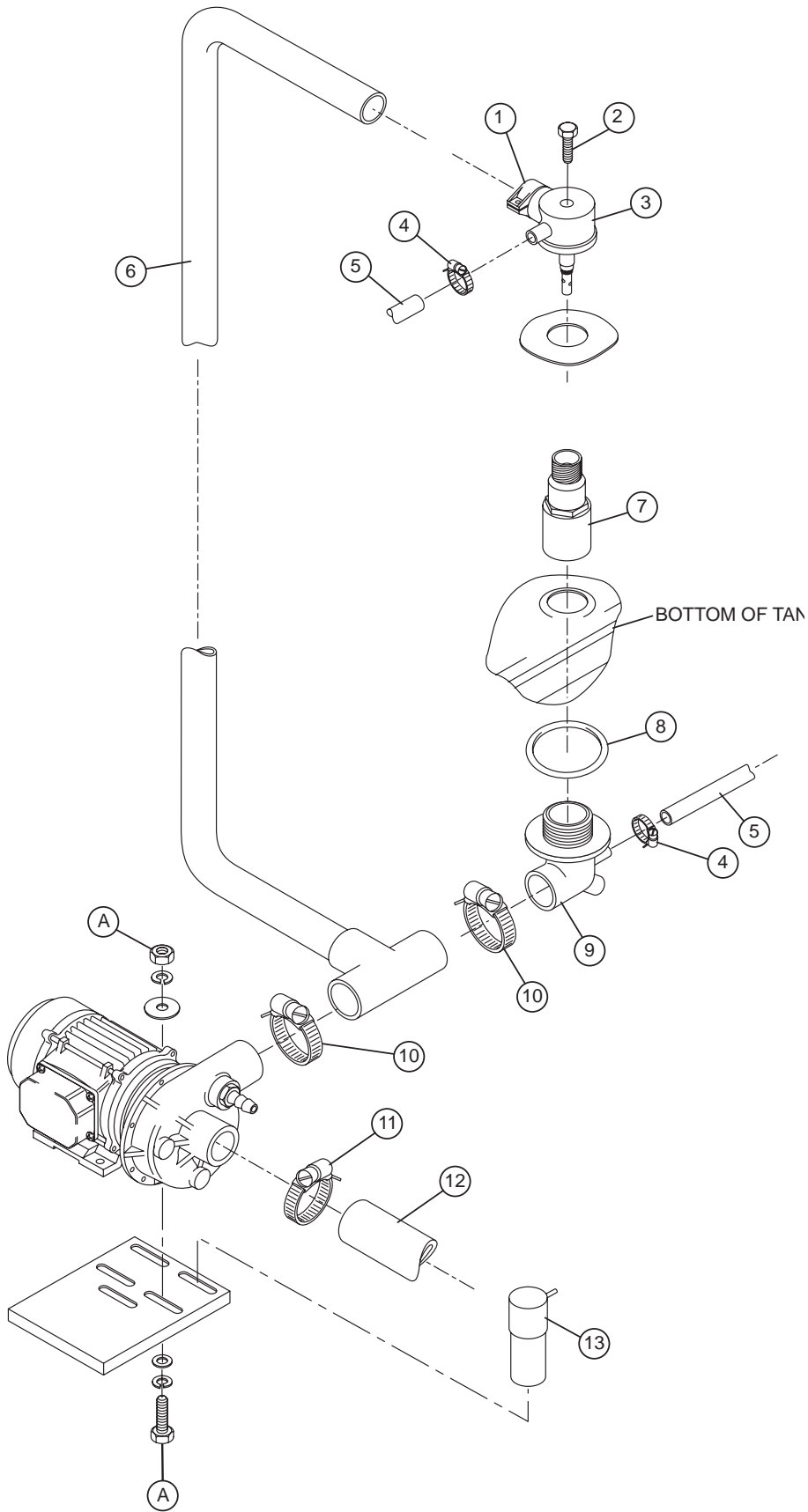

<i>Item No.</i>	<i>Part No.</i>	<i>Description</i>	<i>Qty.</i>	<i>Unit</i>
1	0502563	Jubilee Clip	1	ea
2	110215	Screw SS	1	ea
—	107873	Gasket	1	ea
3	H35509	Hub, Upper Arm	1	ea
4	0503674	Clamp, Hose	2	ea
5	H00182	Hose, Blue Rinse	A/R	ft.
6	H35550	Wash Delivery Sleeve	1	ea
7	H36279	Lower Wash Support	1	ea
8	109466	O-ring	1	ea
9	H36280	Lower Holder Revolving Arm	1	ea
10	0502571	Clamp, Hose	2	ea
11	0512322	Clamp, Hose	1	ea
12	H32894	Suction Hose	1	ea
13	H29043	Capacitor 16 UF/450V	1	ea
A		HARDWARE FOR MOUNTING PUMP		
	H25751	Split Spacer	8	ea
	H25745	Lock Washer	8	ea
	H25730	Hex Screw M8 x 25	4	ea

Wash and Rinse Arm Assemblies

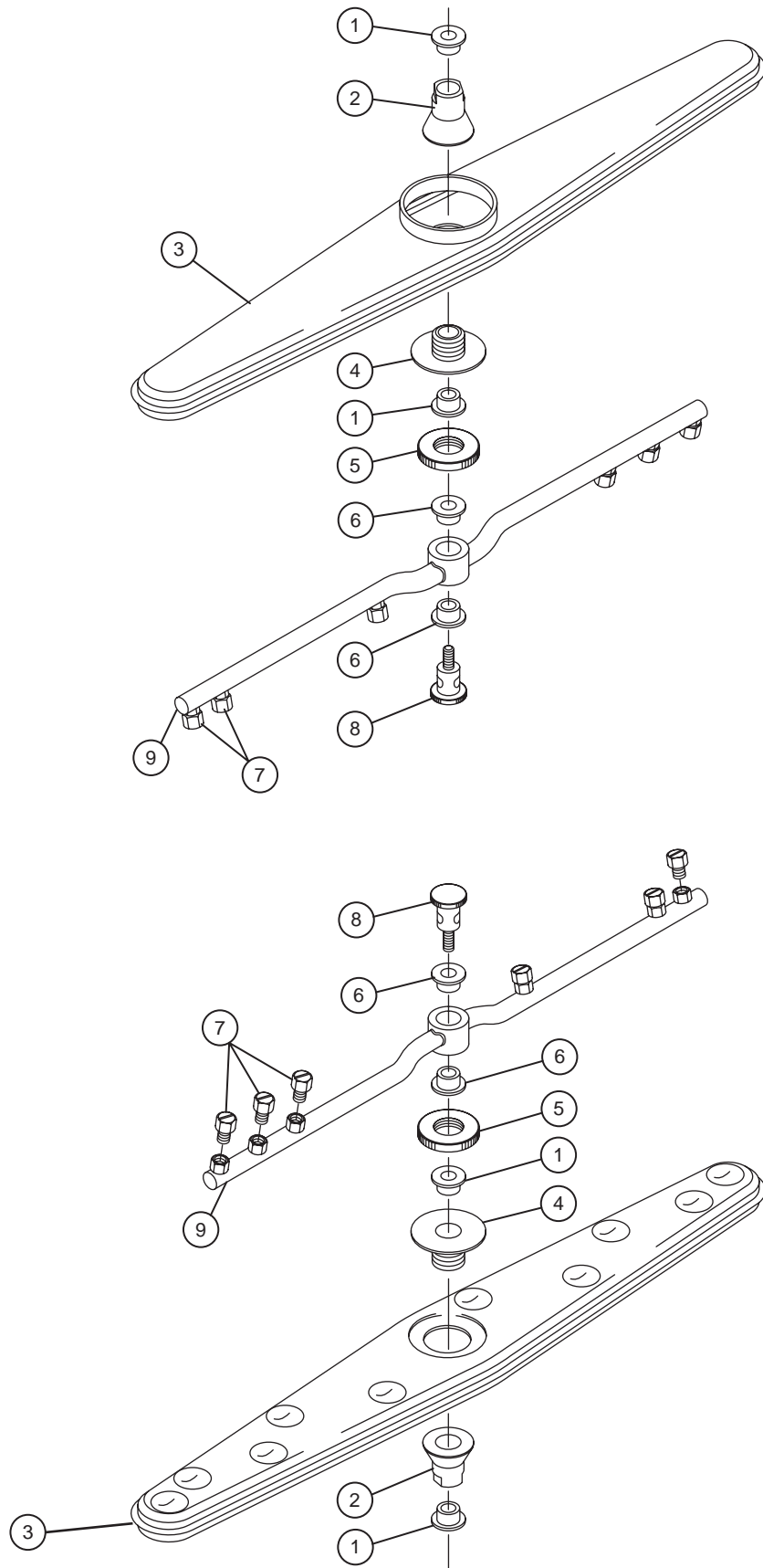

<i>Item No.</i>	<i>Part No.</i>	<i>Description</i>	<i>Qty.</i>	<i>Unit</i>
*1	-----	Bearing, Wash Arm	4	ea
2	112549	Hub, Wash Arm	2	ea
3	H420548	Assy, Wash Arm Complete	2	ea
4	112550	Locknut, Wash Arm	2	ea
5	H34998	Nut Spacer	2	ea
6	H190663	Bushing, Rinse Arm	4	ea
7	H36257	Rinse Nozzle	6	ea
8	H36275	Pin, Revolving Rinse Arm	2	ea
9	H36211	Rinse Arm 301	2	ea

* Use Kit No. 0712749 whenever a wash arm bearing needs to be replaced.

The bearings are pressed into the wash arm hub at the factory to ensure that they are seated properly.

The Kit includes:

Part No.	Description	Qty.
112551	Bearing Wash Arm	2
112549	Hub, Wash Arm	1
112550	Locknut, Wash Arm	1

Wash Pump/Motor Assembly

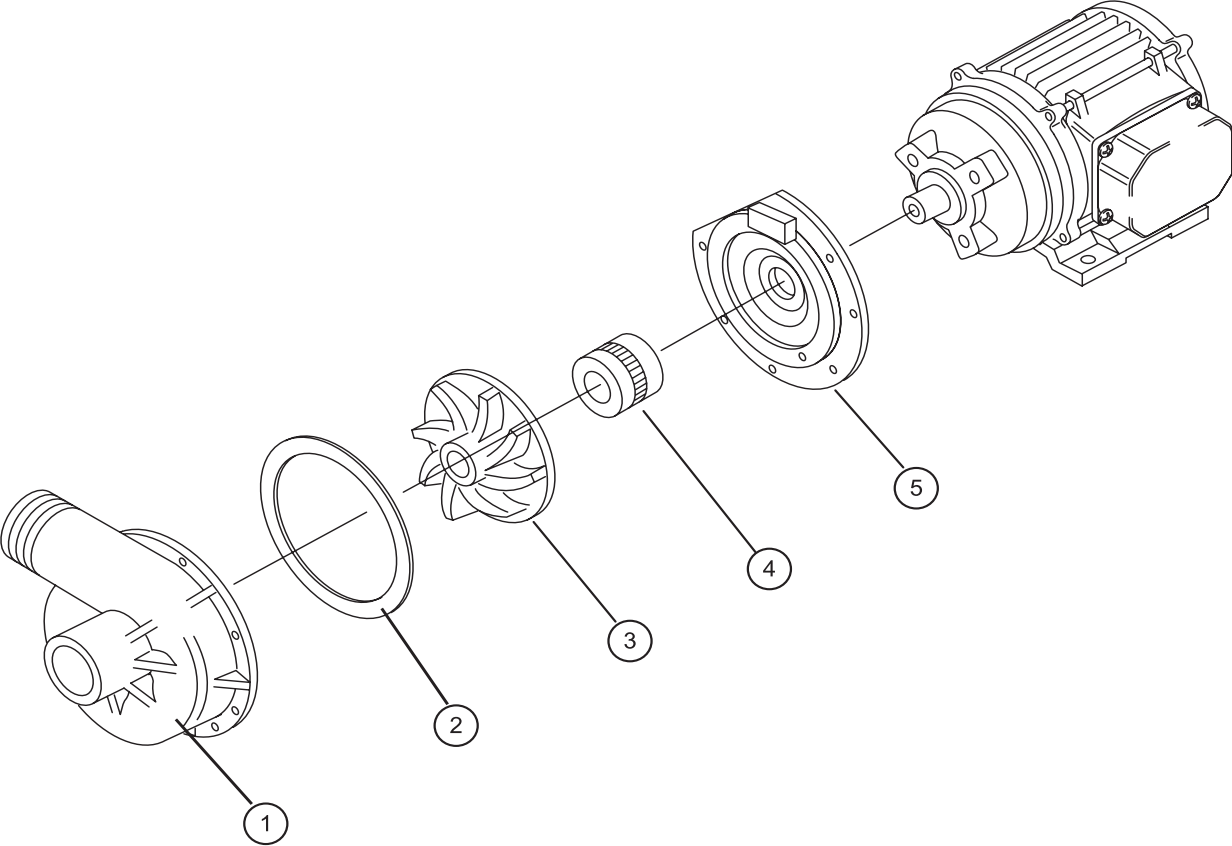

Item No.	Part No.	Description	Qty.	Unit
1	H36354	Pump Body	1	ea
2	110285	Gasket Pump Body	1	ea
3	H26204	Impeller	1	ea
4	H36355	Shaft Seal	1	ea
5	H36356	Flange Wash Pump	1	ea
-	H36129	Wash Pump/Motor Assy. <i>(Includes Items 1-5)</i>	1	ea

Booster Heater Assembly

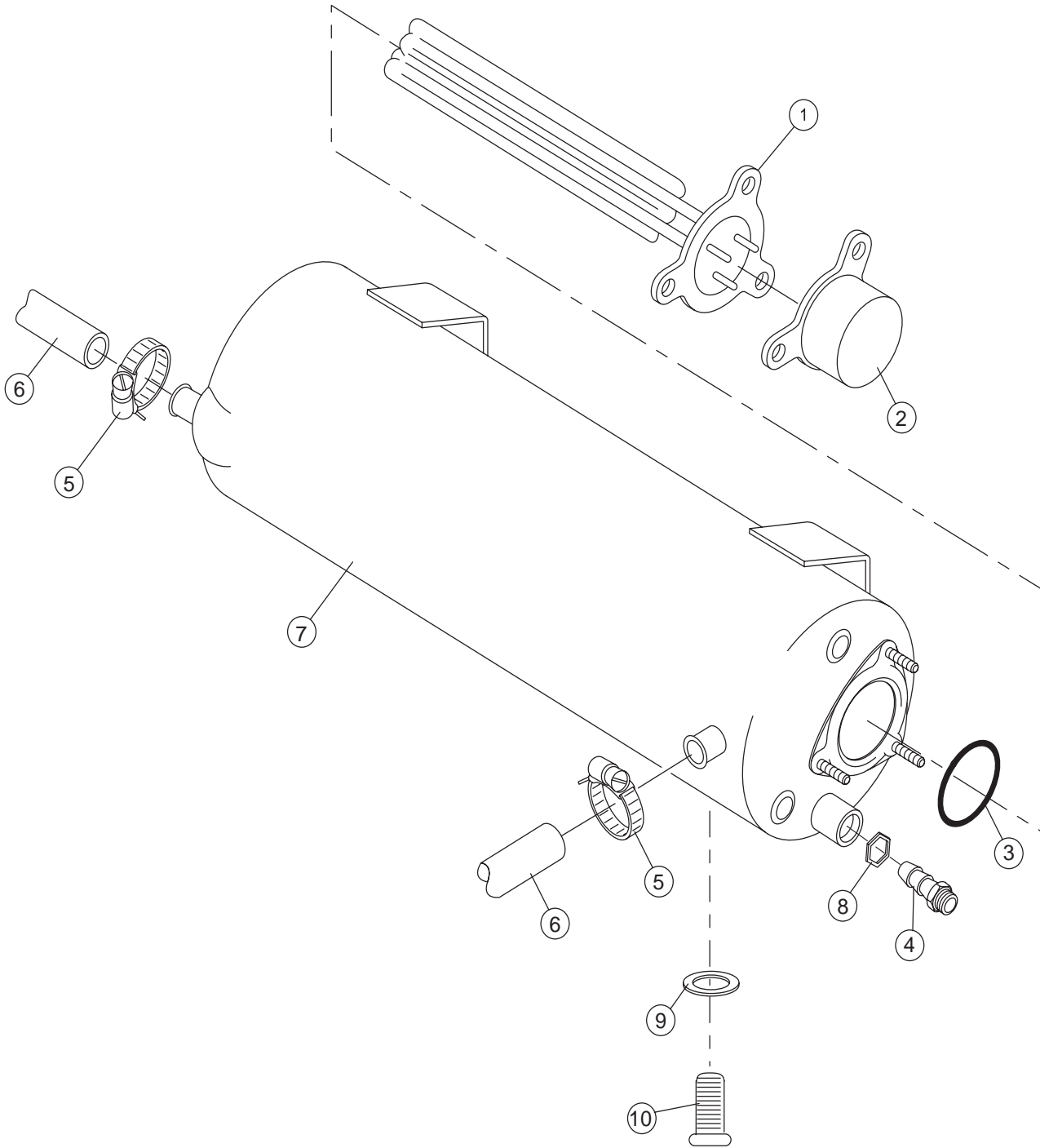

<i>Item No.</i>	<i>Part No.</i>	<i>Description</i>	<i>Qty.</i>	<i>Unit</i>
1	H36250	Heater 4000W 230/380V, 40°F/22°C Rise	1	ea
---	H33400	Heater 6000W 230/380V 70°F/39°C Rise	1	ea
2	H161123	Element Cap	1	ea
3	109985	O-ring	1	ea
4	H35816	Rinse-aid Inlet Fitting	1	ea
5	0503679	Clamp, Hose	2	ea
6	H00182	Hose, Blue	A/R	ft.
7	H36150	Booster Tank	1	ea
8	H34192	Gasket	1	ea
9	H25274	Gasket	1	ea
10	H26863	Drain Plug	1	ea

Control Panel Assembly

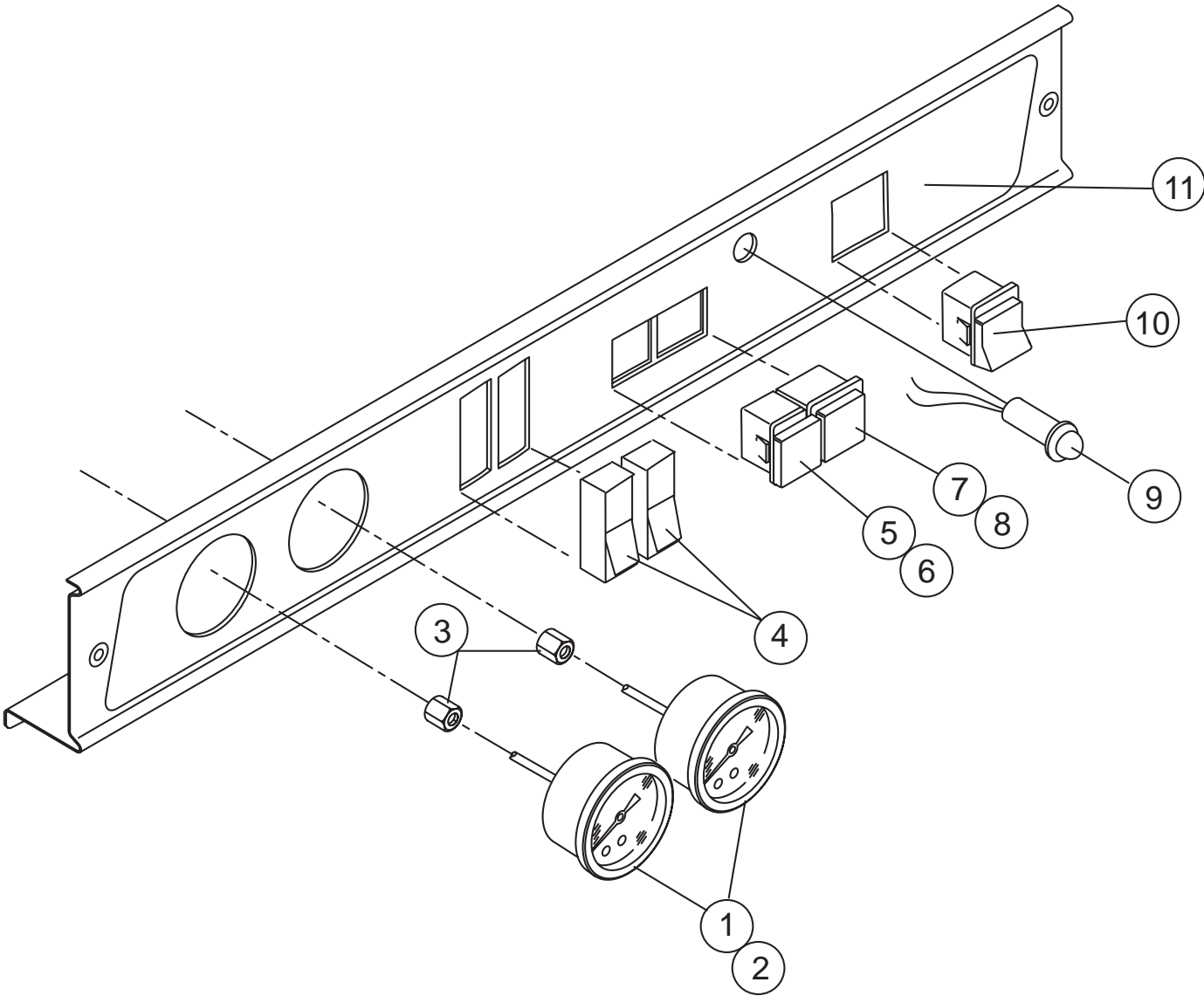

Item No.	Part No.	Description	Qty.	Unit
1	H450916	Thermometer <i>(Does not include Item 3)</i> <i>(Be sure to order Item 3)</i>	2	ea
2	H460344	Plate, Adhesive	2	ea
3	H36607	Packing Nut	2	ea
4	H37169	Prime Switch	2	ea
5	H37179	Drain Switch <i>(Push button only does not include Item 6)</i>	1	ea
6	H32928	Contact Block, Double Pole, Drain Switch	1	ea
7	H37178	Start Switch <i>(Push button only does not include Item 8)</i>	1	ea
8	H32928	Contact Block, Double Pole, Start Switch <i>(Beginning with S/N 66190 and above)</i>	1	ea
9	0512234	Cycle Light	1	ea
10	H37168	Covered On/Off Switch	1	ea
11	H37174	Decal	1	ea

Control Cabinet Assembly

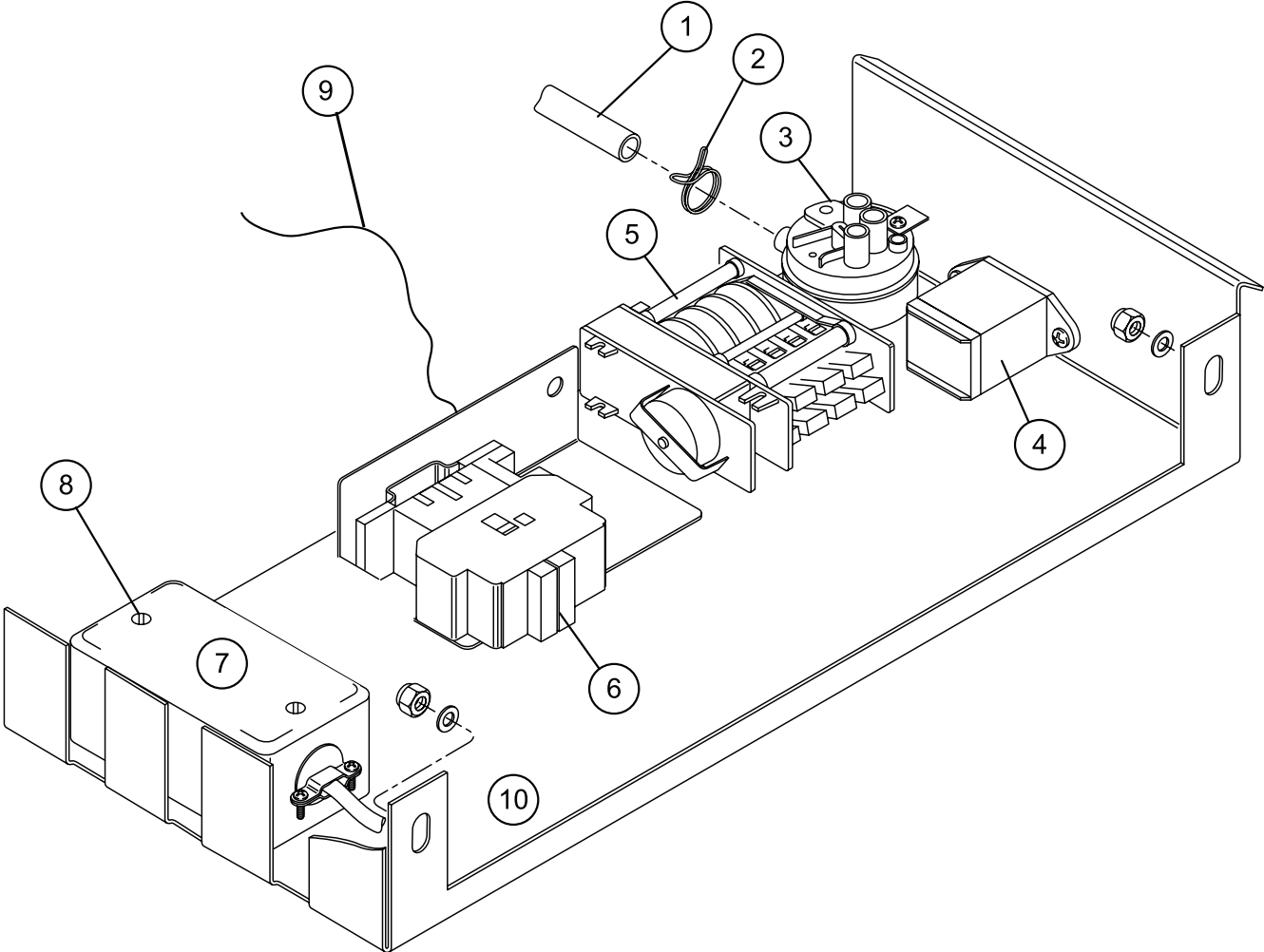

<i>Item No.</i>	<i>Part No.</i>	<i>Description</i>	<i>Qty.</i>	<i>Unit</i>
1	H160121	Hose, Black Rubber	1	ea
2	H31643	Clamp, Hose	1	ea
3	H31171	Pressure Switch	1	ea
4	H34312	Relay 16A 230V	1	ea
5	H36142	Timer 230V 60Hz	1	ea
6	H31982	Booster Heater Contactor 220V	1	ea
7	H36357	Junction Box	1	ea
8	H260248	Screw M5 x12	2	ea
—	—	Terminal Block Earth (Ground)	1	ea
9	H34046	Drawer Stop Rope (Not Shown)	1	ea
10	H33188	Magnetic Switch (Not Shown)	1	ea

***This page
intentionally
left blank***

***Electrical Schematic and
Timing Chart***

LEGEND	
IL	ON/OFF SWITCH
PR	PRESSURE FILL SWITCH
LL	POWER LIGHT
LC	CYCLE LIGHT
CP	DOOR SAFETY SWITCH
TB	BSTR. CONTROL THERMOSTAT
TBS	BSTR. HI-LIMIT THERMOSTAT
TV	WASH CONTROL THERMOSTAT
TVS	WASH HI-LIMIT THERMOSTAT
RB	BOOSTER TANK HEATER
RV	WASH TANK HEATER
EVC	HOT WATER SOLENOID VALVE
MT	TIMER MOTOR
MP	WASH PUMP
M1/4	TIMER CAM SWITCH
ST	CYCLE START SWITCH
R1	AUXILIARY RELAY
STMS	START MANUAL UNLOADING
C1	BOOSTER HEAT CONTACTOR
PD	DETERGENT PUMP
PS	DRAIN PUMP
CD	CAPACITOR 16 mf
PB	RINSE AID PUMP
PIB	RINSE AID SWITCH
PID	DETERGENT PUMP SWITCH

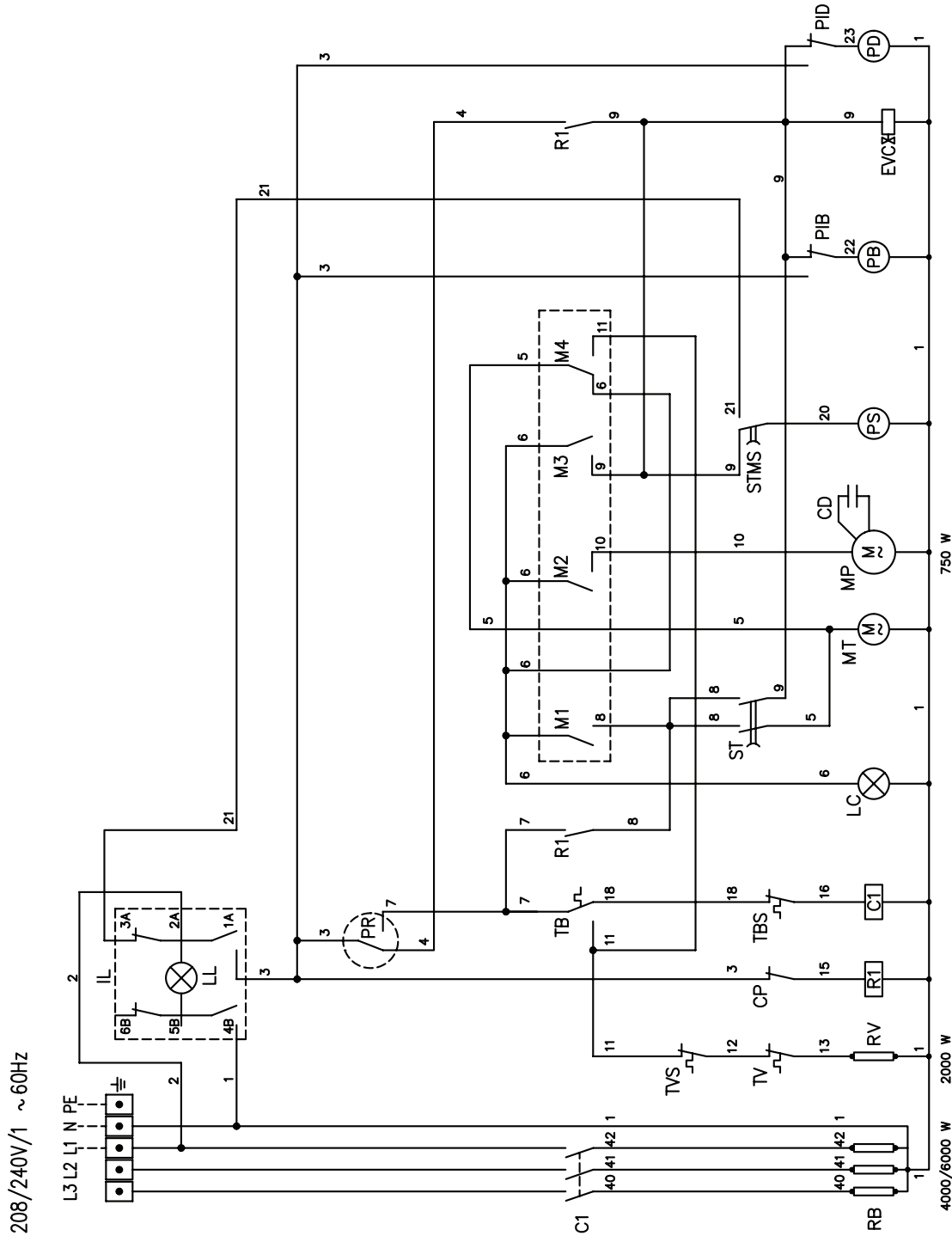

MODEL 301HT Electrical Schematic
Manual Revised July 19, 2006

TIMING CHART

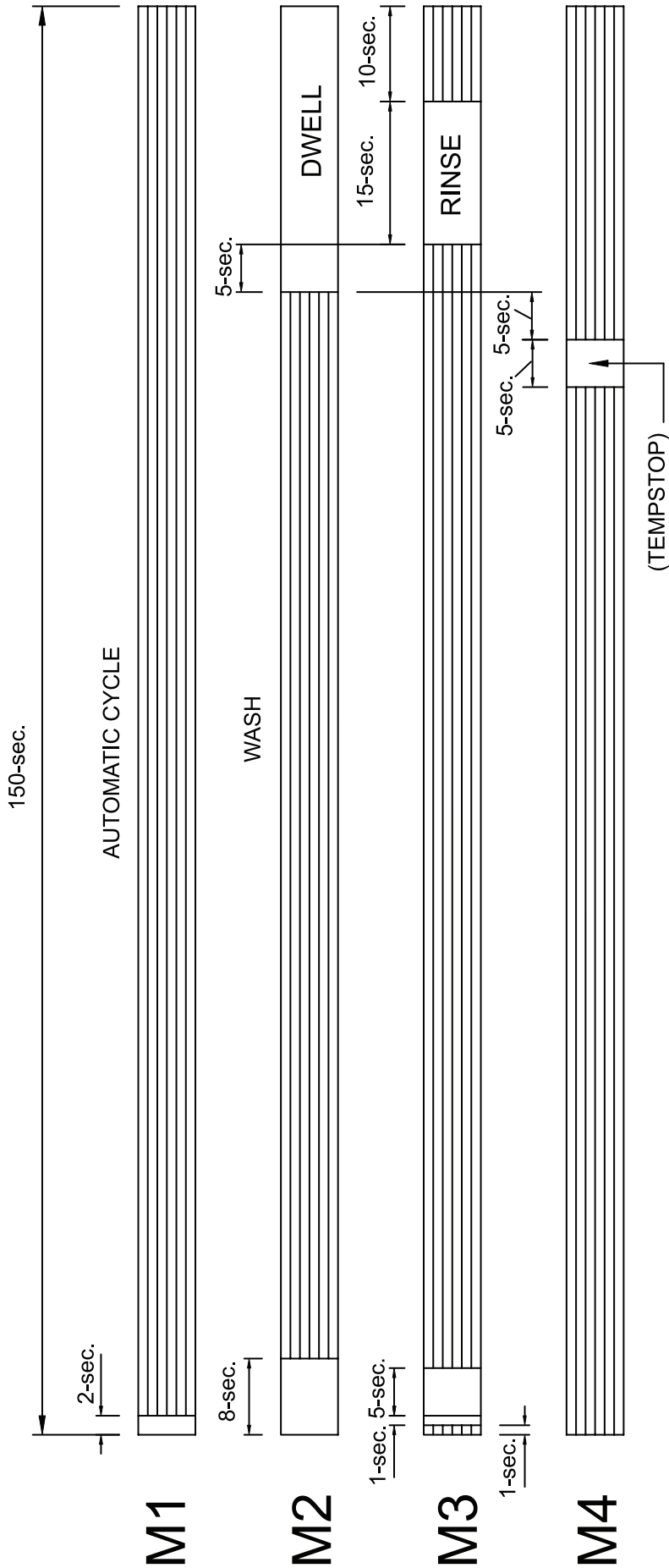

TIMER MOTOR OFF = RINSE SENTRY
 DELAY FOR THE FINAL
 RINSE BOOSTER TO
 REACH TEMPERATURE

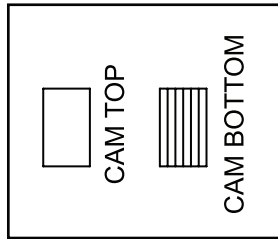
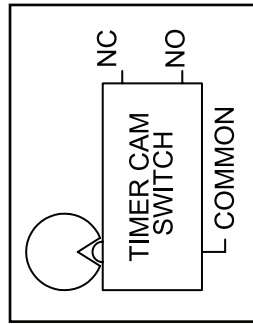

MODEL 301HT Electrical Schematic
 Manual Revised July 19, 2006

