



Simply Engineered Better

For machines beginning with Serial No. W8100

Technical Manual



Hood-Type Dishwasher

Model

MH65-M2

High Temperature
with Built-in Booster

Machine Serial No.

September, 2003

P. O. Box 4149
Winston-Salem, North Carolina 27115-4149
336/661-1556 Fax: 336/661-1660

Manual P/N 113647

2674 N. Service Road
Jordan Station, Ontario, Canada L0R 1S0
905/562-4195 Fax: 905/562-4618

Moyer Diebel Ltd.

Complete the information below for quick reference.

Model Number _____ Serial Number _____

Voltage and Phase _____

Moyer Diebel Parts Supplier _____ Phone _____

Moyer Diebel Service Agency _____ Phone _____

Moyer Diebel Service:

Moyer Diebel (USA)

Phone: 1 (336) 661-1556

1 (800) 858-4477

Fax: 1 (336) 661-1660

Moyer Diebel Limited (Canada)

Phone: 1 (905) 562-4195

1 (800) 263-5798

Fax: 1 (905) 562-4618

Note: When calling to order parts, be sure to have the model number, serial number, voltage and phase of your machine.



Machine Data Plate with
model & serial number
located on the right side
panel at the top.

REVISION RECORD

Revision Date	Revised Pages	Serial Number Effectivity	Comments
7/3/03	All	W8100	First issue of manual and replacement parts lists

Revision Record (CONT.)

Limited Warranty

Moyer Diebel, P.O. Box 4183, Winston-Salem, North Carolina 27115, and P. O. Box 301, 2674 North Service Road, Jordan Station, Ontario, Canada L0R 1S0 warrants machines, and parts, as set out below.

Warranty of Machines: Moyer Diebel warrants all new machines of its manufacture bearing the name "Moyer Diebel" and installed within the United States and Canada to be free from defects in material and workmanship for a period of one (1) year after the date of installation or fifteen (15) months after the date of shipment by Moyer Diebel, whichever occurs first. [See below for special provisions relating to Model Series DF and SW.] The warranty registration card must be returned to Moyer Diebel within ten (10) days after installation. If warranty card is not returned to Moyer Diebel within such period, the warranty will expire after one year from the date of shipment.

Moyer Diebel will not assume any responsibility for extra costs for installation in any area where there are jurisdictional problems with local trades or unions.

If a defect in workmanship or material is found to exist within the warranty period, Moyer Diebel, at its election, will either repair or replace the defective machine or accept return of the machine for full credit; provided, however, as to Model Series DF and SW, Moyer Diebel's obligation with respect to labor associated with any repairs shall end (a) 120 days after shipment, or (b) 90 days after installation, whichever occurs first. In the event that Moyer Diebel elects to repair, the labor and work to be performed in connection with the warranty shall be done during regular working hours by a Moyer Diebel authorized service technician. Defective parts become the property of Moyer Diebel. Use of replacement parts not authorized by Moyer Diebel will relieve Moyer Diebel of all further liability in connection with its warranty. In no event will Moyer Diebel's warranty obligation exceed Moyer Diebel's charge for the machine. The following are not covered by Moyer Diebel's warranty:

- a. Lighting of gas pilots or burners.
- b. Cleaning of gas lines.
- c. Replacement of fuses or resetting of overload breakers.
- d. Adjustment of thermostats.
- e. Adjustment of clutches.
- f. Opening or closing of utility supply valves or switching of electrical supply current.
- g. Adjustments to chemical dispensing equipment.
- h. Cleaning of valves, strainers, screens, nozzles, or spray pipes.
- i. Performance of regular maintenance and cleaning as outlined in operator's guide.
- j. Damages resulting from water conditions, accidents, alterations, improper use, abuse, tampering, improper installation, or failure to follow maintenance and operation procedures.

Examples of the defects not covered by warranty include, but are not limited to: (1) Damage to the exterior or interior finish as a result of the above, (2) Use with utility service other than that designated on the rating plate, (3) Improper connection to utility service, (4) Inadequate or excessive water pressure, (5) Corrosion from chemicals dispensed in excess of recommended concentrations, (6) Failure of electrical components due to connection of chemical dispensing equipment installed by others, (7) Leaks or damage resulting from such leaks caused by the installer, including those at machine table connections or by connection of chemical dispensing equipment installed by others, (8) Failure to comply with local building codes, (9) Damage caused by labor dispute.

Warranty of Parts: Moyer Diebel warrants all new machine parts produced or authorized by Moyer Diebel to be free from defects in material and workmanship for a period of 90 days from date of invoice. If any defect in material and workmanship is found to exist within the warranty period Moyer Diebel will replace the defective part without charge.

DISCLAIMER OF WARRANTIES AND LIMITATIONS OF LIABILITY. MOYER DIEBEL'S WARRANTY IS ONLY TO THE EXTENT REFLECTED ABOVE. CHAMPION MAKES NO OTHER WARRANTIES, EXPRESS OR IMPLIED, INCLUDING, BUT NOT LIMITED, TO ANY WARRANTY OF MERCHANTABILITY, OR FITNESS OF PURPOSE. MOYER DIEBEL SHALL NOT BE LIABLE FOR INCIDENTAL OR CONSEQUENTIAL DAMAGES. THE REMEDIES SET OUT ABOVE ARE THE EXCLUSIVE REMEDIES FOR ANY DEFECTS FOUND TO EXIST IN MOYER DIEBEL DISHWASHING MACHINES AND MOYER DIEBEL PARTS, AND ALL OTHER REMEDIES ARE EXCLUDED, INCLUDING ANY LIABILITY FOR INCIDENTALS OR CONSEQUENTIAL DAMAGES.

Moyer Diebel does not authorize any other person, including persons who deal in Moyer Diebel Dishwashing Machines to change this warranty or create any other obligation in connection with Moyer Diebel Dishwashing Machines.

FOREWORD

1. Read the instructions in this manual carefully. It contains important information on installation, operation, and safety.
2. Store this manual carefully for future reference.
3. After removing packing material, check for loose parts in dishracks.
4. Before switching the equipment on, make sure that the model data plate conforms to the electrical and water requirements supplied to this particular machine.
5. Installation should be carried out by qualified personnel according to the manufacturer's instructions. The installation of your machine must meet all applicable health and safety codes.
6. This equipment should be used for its intended purpose. Any other application should be considered improper and therefore dangerous.
7. Only trained personnel should operate this equipment.
8. Operators must strictly follow all hygienic requirements in the handling of clean dishware or cutlery.
9. Do not leave the machine in an environment at temperatures lower than 0°C/32°F.
10. This machine should not be washed with a direct water stream.
11. Only qualified personnel should access the control panel after disconnecting main power supply. Tag the disconnect indicating work is being performed on that circuit.
12. Noise level of the machine is less than 67dB.

The manufacturer declines any responsibility for any printing errors contained in this booklet.

The manufacturer also reserves the right to make any modifications to its products that do not affect the basic characteristics thereof.

TABLE OF CONTENTS	PAGE
Revision Record	i
Limited Warranty	iii
Foreward	iv
<hr/>	
INTRODUCTION	1
GENERAL	2
PART 1: OPERATION	3
PART 2: INSTALLATION AND MAINTENANCE	8
PART 3: REPLACEMENT PARTS	11
PART 4: ELECTRICAL SCHEMATICS	39

LIST OF FIGURES

Figure 1.1 – Operations Detail	3
Figure 1.2 – Control Panel Detail	7
Figure 3.1 – Hood and Tank	12
Figure 3.2 – Door Handle and Springs	14
Figure 3.3 – Door Switch and Block	16
Figure 3.4 – Tracks and Screens	18
Figure 3.5 – Wash and Rinse Spray Arms	20
Figure 3.6 – Water Tank Components	22
Figure 3.7 – Drain Assembly	24
Figure 3.8 – Wash and Rinse Piping	26
Figure 3.9 – Wash Pump Assembly	28
Figure 3.10 – Booster Assembly	30
Figure 3.11 – Water Inlet Piping	32
Figure 3.12 – Control Panel	34
Figure 3.13 – Control Cabinet	36

**This Page
Intentionally
Left
Blank**

INTRODUCTION

Welcome to **Moyer Diebel**... and thank you for allowing us to take care of your dishwashing needs.

This manual covers the hood-type dishwasher model MH-65.

Your machine was completely assembled , inspected and thoroughly tested at our factory before it was shipped to your installation site.

This manual contains:

- Installation and Instructions
- Operation and Cleaning Instructions
- Troubleshooting Guide
- Basic Service Information
- Replacement Parts Lists
- Electrical Schematics

All information, illustrations and specifications contained in this manual are based upon the latest product information available at the time of publication. **Moyer Diebel** constantly improves its products and reserves the right to make changes at any time or to change specification without notice and without incurring any obligations.

For your protection, factory authorized parts should always be used for repairs.

Replacement parts may be ordered from your **Moyer Diebel** authorized parts distributor or authorized service agency. When ordering parts, please supply the model number, serial number, voltage and phase of your machine, the part number, part description and quantity.

MODEL NUMBERS

MH-65

The MH-65 model is a high temperature (180°F/82°C rinse) sanitizing model with booster.

Standard Equipment Includes:

- Quick 65 second cycle
- Four large rectangular screens to maximize food soil collection and improve resistance to clogging
- Variable selector switch for 65, 120 and 180 seconds cycles
- Single electrical and water connections for machine and booster
- Automatic tank fill/low-tank water heat protection
- Detergent probe and rinse-aid connection points provided
- 1.5 HP wash pump on anti-vibration pads
- Field convertible from straight through to corner operation
- Extended wash/de-lime cycles (for heavily soiled items)
- Door safety switch
- Pressure Reducing Valve provided
- Interchangeable upper and lower wash and rinse arms

Options

- Electric booster (70°F/39°C temperature rise) heater for 110°F/43°C supply water

Accessories

Additional dishracks:

Dish rack (peg) P/N 101285

Silverware rack (flat bottom) P/N 101273

Electrical Power Requirements: Fig Elec Heat/Electric Booster

Model	Voltage	Booster Rise	Rated Amps	Minimum Supply Ckt. Conductor Ampacity	Maximum Overcurrent Protective Device
MH-65	208/60/1	40	45 Amps	60 Amps	60 Amps
MH-65	240/60/1	40	51 Amps	70 Amps	70 Amps
MH-65	208/60/3	40	26 Amps	35 Amps	35 Amps
MH-65	240/60/3	40	29 Amps	40 Amps	40 Amps
MH-65	208/60/3	70	37 Amps	50 Amps	50 Amps
MH-65	240/60/3	70	42 Amps	60 Amps	60 Amps

PART 1: OPERATION

OPERATION AND USE

- Before washing make sure that:
 - the wall-mounted on/off switch is switched on;
 - the water tap is open and water pressure is present,
 - the pump suction filters are installed in their proper locations;
 - the overflow tube is inserted in the drain;
 - rotating spray arms move freely;
 - the rinse and detergent containers are full;
- Set switch "A" to position 1 to enable the automatic filling of the wash tank. Once the wash tank has filled and the tank heater turns on to make the tank reach temperature, the heater then turns off and lamp "B" turns on **(this applies only to machines in the serial number range W8100 to W8135)**.

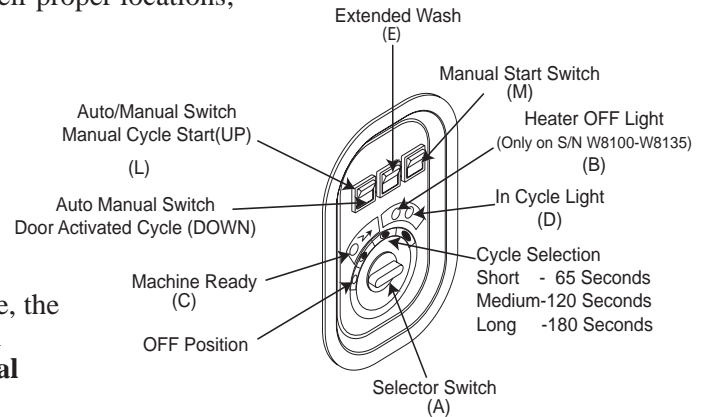

Figure 1.1 Operation Detail

- Scrap and preflush all items to be washed and load the items into the rack. Do not overload the rack. Wash only one layer of silverware in a rack.
- Open the door and insert the rack into the machine.
- By means of switch "A" select the wash cycle according to conditions of the dishware:
 - with glasses or cups select the short cycle (pos.1)
 - with normally dirty dishes or cutlery select the medium cycle (pos.2)
 - with particularly dirty dishes or deep dishes select the long cycle (pos.3), or flip the extended wash switch (E) down (only after starting a cycle). This will make the dishmachine cycle in wash continuously until (E) is flipped up again; the machine will then resume its normal cycle.
- By means of selector "L", select the wash cycle for automatic start when the hood is closed, or for manual start by pressing the button "M". Lamp "D" will switch off at the end of the cycle.



NOTE:

This machine will continue to wash until the booster tank reaches temperature and the thermostat shuts off; only then will the machine proceed to the rinse cycle.

PART 1: OPERATION (CONT.)

OPERATION AND USE (CONT.)

7. Remove the rack at a slight incline to permit all the water to drain; allow dishware to dry. After washing one's hands, handle the rack in such a manner as not to touch the dishware inside, then place the rack on hygienically clean shelves.
8. At the end of washing, turn switch "A" to position "0", empty out the tank by removing the overflow tube. Then close the door and turn switch "A" to position "1" for a few minutes to rinse out the inside of the machine. Finally, turn the switch "A" to position "0" and wait until the tank is completely empty.
The scrap screens can now be taken out, washed, and then replaced.
Be certain that the overflow tube has been reinstalled.
9. When finished washing, switch off the machine by turning off the main disconnect switch and turn off the water supply.

INSTRUCTIONS DURING THE WASH CYCLE

1. Do not put your hands into the water containing detergent. If this happens, wash them immediately and thoroughly with fresh water.
2. Use only commercial non-foaming detergents.
3. When the machine is operating, do not open the door too quickly.
4. In the event the machine does not work properly, turn off the main power disconnect switch and contact a technical service center authorized by the manufacturer for repairs.
5. Never modify the thermostat settings.
6. Wash tank water should be changed every two hours or after each meal period.
7. Do not subject clean dishware to any further cleansing treatment such as brushes or drying towels.



CAUTION:

If these instructions are not followed, your safety and the equipment can be compromised.

MAINTENANCE:

IMPORTANT:

Before carrying out the cleaning and maintenance operations, turn off the main disconnect switch for the equipment.

Frequently check and clean the nozzles. Blocked nozzles will prevent the machine from cleaning properly.

Do not use corrosive products such as sodium hypochlorite (bleach), acids, steel wool or steel brushes to clean the inside and outside of the machine.

The presence of calcium and magnesium salt in the water can compromise machine performance. Ask a qualified chemical person to remove the deposits periodically.

Stainless steel surfaces should be well cleaned in order to avoid some oxidation risks, or chemical reactions.

OPTIMAL RESULTS:

Poor wash results can be noted when residue remains on the dishware.

Poor results can be caused by an insufficient rinse: in this case check that the rinse nozzles are clean and that there is sufficient water supply pressure (20-22 PSI/138-151 kPa) during machine rinse cycle..

In case of dishware residue check that:

- the washing nozzles are clean
- the wash water temperature is a minimum of 60°C/140°F
- there is detergent in the container
- the pump suction filter is clean
- the racks are suitable for the dishes and cutlery that are to be washed
- the position of the cutlery and the dishes in the racks are correct
- the racks are not overloaded with wares

TEMPORARY MACHINE NONUSE:

In case the machine is not used for a prolonged period, it is recommended to fill the wash tank and run the machine with clean water, then drain, in order to avoid the forming of bad odors.

If necessary repeat this step until all water leaving the machine is clean.

If the machine is not used for long periods, it is recommended to oil the stainless steel surfaces with paraffin oil and to empty the water from the booster tank and the wash pump.

PART 1: OPERATION (CONT.)

OPERATION AND USE (CONT.)

SANITIZING THE MACHINE

Sanitizing the machine at least once a week is of the utmost importance in order to guarantee hygiene, even when the machine is not in use.

It is advisable to use a disinfecting product suggested by an authorized detergent dealer.

Before turning off the machine, run the machine briefly with clean water.

HARD WATER CONDITIONS

In hard water locations, mineral deposits will form inside the machine and also on dishware.

In order to avoid the above conditions delime the machine on a regular basis.

PART 1: OPERATION (CONT.)

OPERATION AND USE (CONT.)

CONTROL PANEL LAYOUT

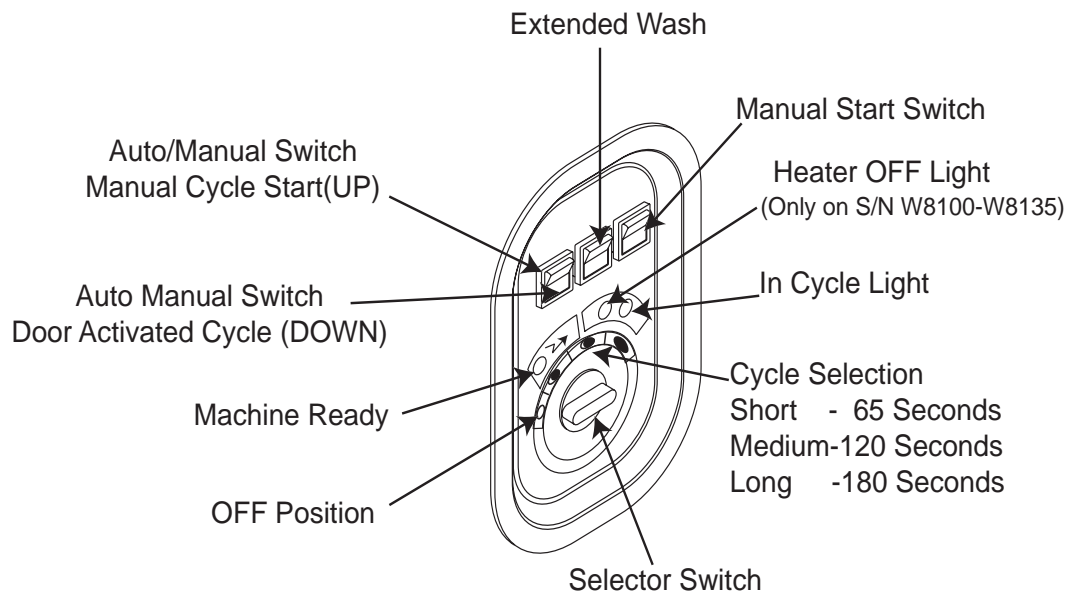

Figure 1.1-
Control Panel Detail

1. Close door.
2. To fill the machine, set the selector switch to any of the three positions. When the automatic fill is complete, the wash tank heater will cut on until the tank reaches temperature. Then the indicator light will turn on (**this only applies to machines in the serial number range W8100 to W8135**).
3. Scrap and preflush all items to be washed and load the items into the rack. **DO NOT OVERLOAD THE RACK. Wash** cutlery and place upright in cutlery baskets.
4. Open the door and insert the rack into the machine.
5. With the selector switch choose the desired cycle time.
6. To start the cycle:
 - For Manual Cycle Start, push the auto/manual switch to the up position. Push the Manual Start Button.
 - For Door Activated Start, push the auto/manual switch to the down position. Cycle will start when the door is closed.



NOTE:

Machine must be in cycle prior to activating the extended wash.



NOTE:

This machine will not begin the rinse cycle until the rinse water reaches 180°F/82°C.

PART 2: INSTALLATION AND MAINTENANCE

INSTALLATION AND MAINTENANCE INSTRUCTIONS

The following instructions are addressed to qualified personnel. Only authorized personnel are to carry out checks and repairs.

The manufacturer declines any responsibility if repairs or modifications are done by unqualified personnel or if parts are not supplied by the manufacturer.

Installation

Level the machine by placing a level on the top of the machine and adjusting the feet. Level the machine front to back and side to side.

In order to prevent damage from steam going out of the machine, the walls surrounding the machine should be water resistant material.

After machine installation, check that thermostat settings are correct.

- Booster 180°F/82°C.
- Wash tank 150°F/68°C.

Electrical connections



WARNING:

Electrical and grounding connections must comply with all applicable electrical codes.



WARNING:

When working on the dishwasher, disconnect the electrical service and place a tag at the disconnect switch to indicate that work is being done on that circuit.

1. A qualified electrician must compare the electrical power supply with the machine electrical specifications before connecting to the incoming service through a fused disconnect switch.
2. A fused disconnect switch or circuit breaker (supplied by others) is required to protect the power supply circuit.

Plumbing connections

1. The MH-65 series dishwasher requires a single hot water supply.

Install a water shut off valve with a 3/4" NPT hose connection within 40" (1016mm) of the machine. A 6 ft. (1829mm) hose with a 3/4" NPT hose connector is supplied to connect to customers supply valve. Water temperature must be minimum 140°F/60°C for 40° rise machines and 110°F/43°C for 70° rise machines at 20-22 PSI/138-151 kPa flow rate.

2. Install the supplied 3/4" pressure reducing valve (PRV) in the water supply line if the flow pressure exceeds 20-22 PSI/138-151 kPa.

PART 2: INSTALLATION AND MAINTENANCE (CONT.)

Drain connections

1. The MH65 model is a gravity drain machine equipped with a 1-3/8" O.D. tailpiece and a 6 foot long 1" I.D. hose.
2. The maximum drain flow rate is 15 gallons/min-56.8 litres/min.
3. Drain height must not exceed 11" (280mm) above finished floor.
4. The drain connection is made to the dishwasher from underneath the machine through an access hole in the machine base.

Ventilation



NOTE:

Ventilation must comply with local sanitary and plumbing codes.



CAUTION:

Exhaust air should not be vented into a wall, ceiling, or concealed space of a building. Condensation can cause damage.

**This Page
Intentionally
Left
Blank**

PART 3:

REPLACEMENT PARTS

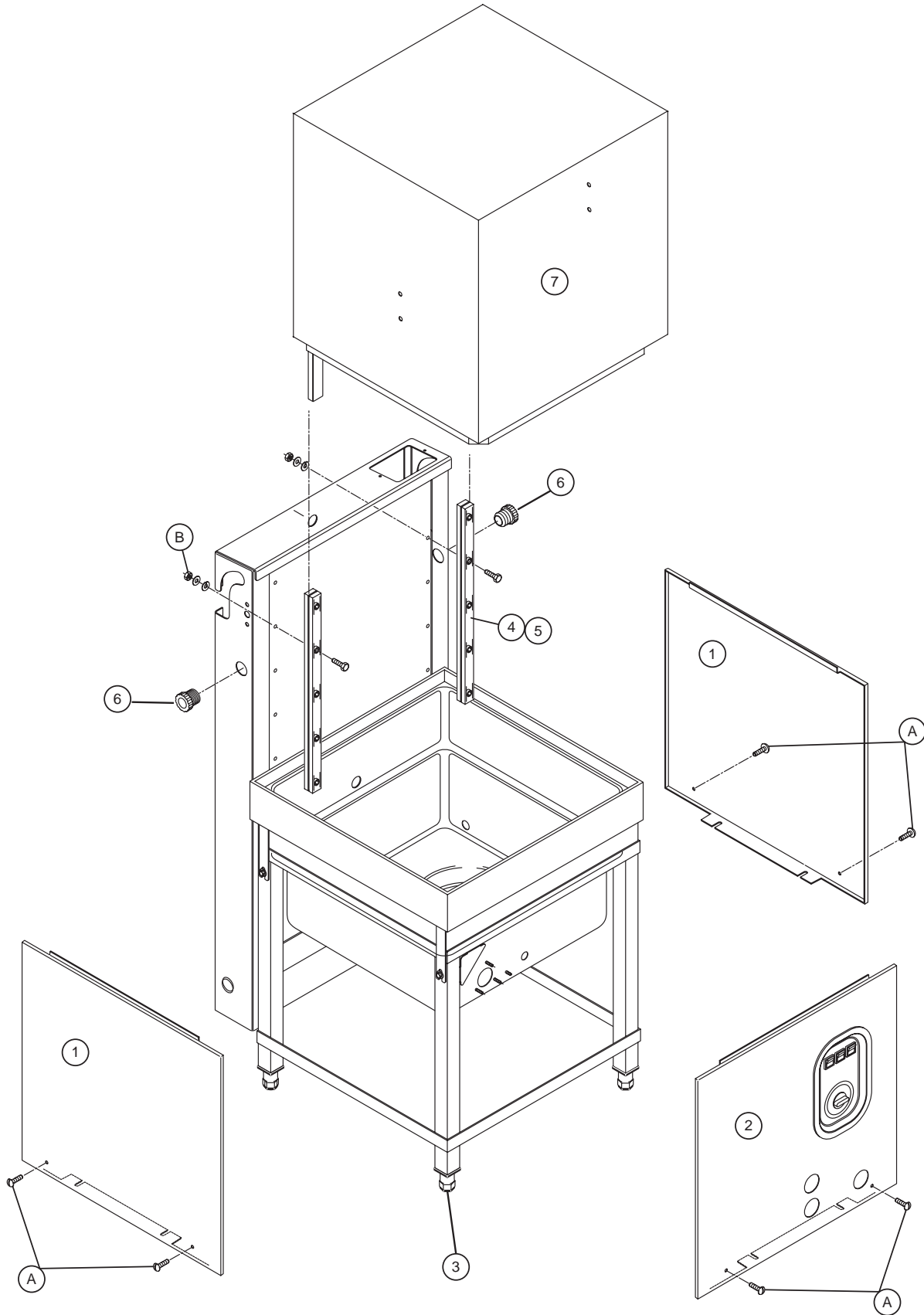

Figure 3.1- Hood and Tank

HOOD AND TANK

Fig. 3.1 Item No.	Part No.	Part Description	Qty
1	C351421	Panel, Side	2
2	C351835	Panel Front	1
3	C440211	Leg	4
4	C180642	Guide, Plastic	2
5	C200957	Gasket, Guide Plastic	2
6	C160737	Plastic Plug.....	2
7	C342497	Hood	1

A **HARDWARE FOR PANELS (Quantities per panel)**

C260129	Screw	2
0501476	Washer, SS 9/32 x 5/8 OD	2
108441	Nut, Hex M5	2

B **HARDWARE FOR PLASTIC GUIDES (Quantities per guide)**

C260219	Screw, M6 x 35 Fillister Head	6
C260504	Washer	6
C260512	Washer, Lock	6
107435	Nut, M6	6

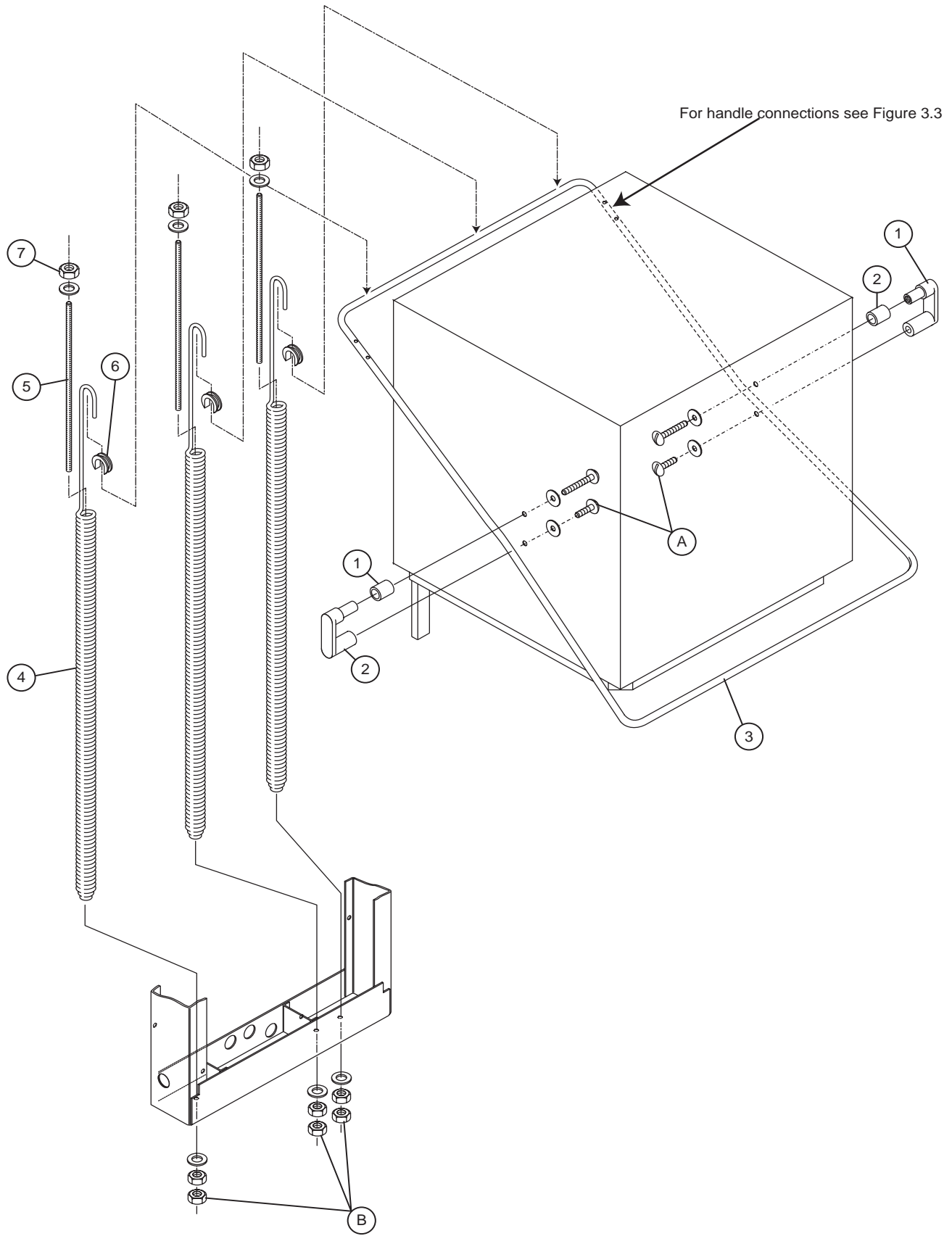

Figure 3.2- Door Handle and Springs

DOOR HANDLE AND SPRINGS

Fig. 3.2 Item No.	Part No.	Part Description	Qty
1	107398-1	Door Lift Block	2
2	107398-2	Door Lift Block Roller	2
3	C331037	Handle	1
4	C391316	Spring, Hood Lift	3
5	C330239	Rod, Threaded Spring Extension	3
6	107397	Block, Spring Hook	3
7	C260415	Nut	3

A **HARDWARE FOR DOOR LIFTS (Quantities per lifts)**

110383	Screw, M8 x 12 Pan Head	2
108022	Washer, M8 Plastic	2

B **HARDWARE FOR THREADED RODS (Quantities per rod)**

C260406	Nut,	2
C260505	Washer	2

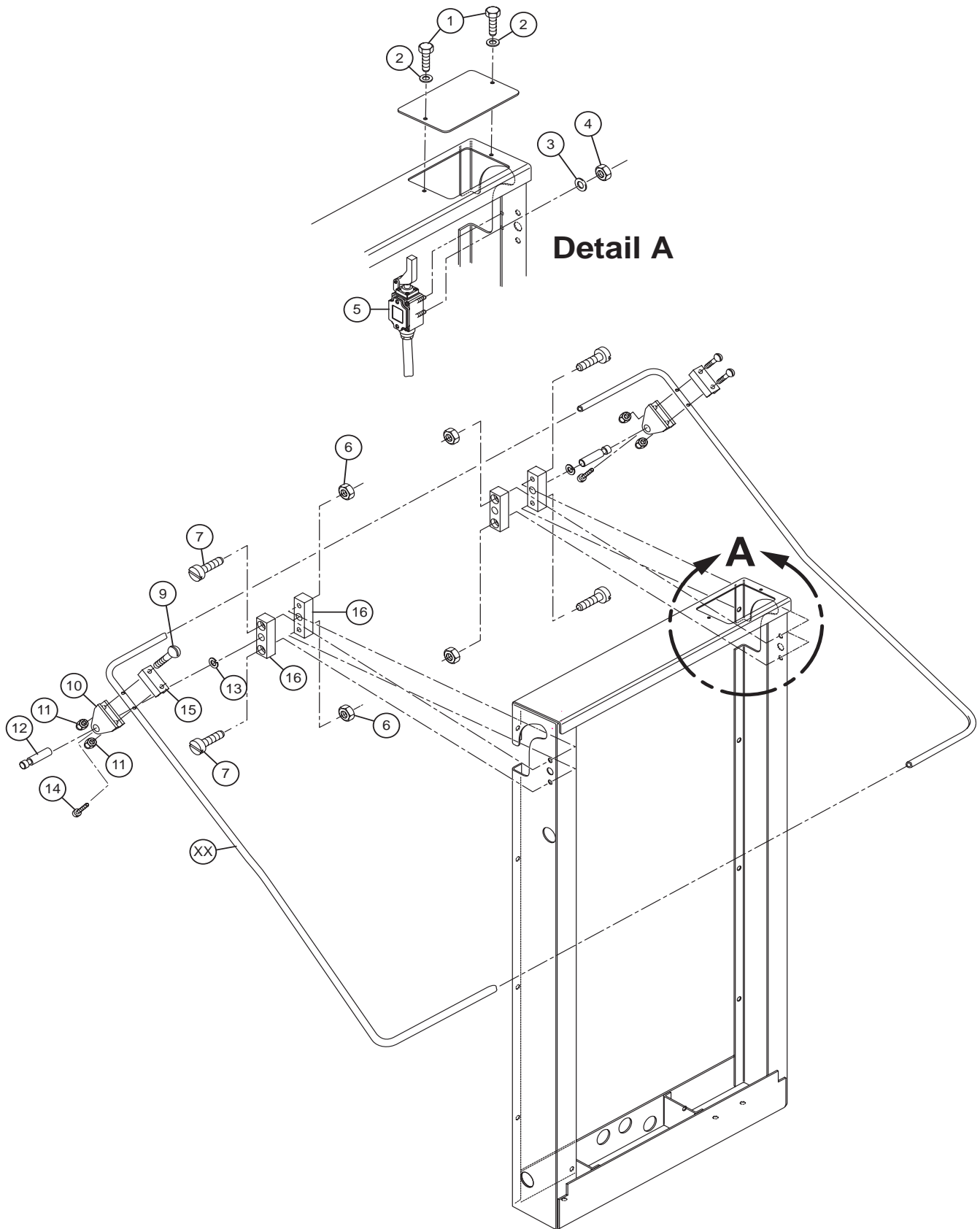

Figure 3.3- Door Switch and Block

DOOR SWITCH AND BLOCKS

Fig. 3.3 Item No.	Part No.	Part Description	Qty
1	108442	Bolt M5 x 15mm Filister Head	2
2		Washer	2
3		Washer	1
4		Nut	1
5	C120343	Switch, Hood Activated	1
6	110214	Nut, Dull M6	4
7	C260219	Screw, M6 x 35	4
8		Screw	8
9	107437	Bolt, M6 x 45	4
10	107395	Block, Pivot Lower	4
11	107420	Nut, Plain M6 SST	4
12	107393	Pin, Pivot Hood	2
13	C260537	Pivot Spacer	2
14	107436	Screw, M6 x 16 Fillister Head	2
15	107396	Block, Pivot Top	2
16	C190149	Pivot Block, Hood Frame	4
17	331037	Handle, Hood	1

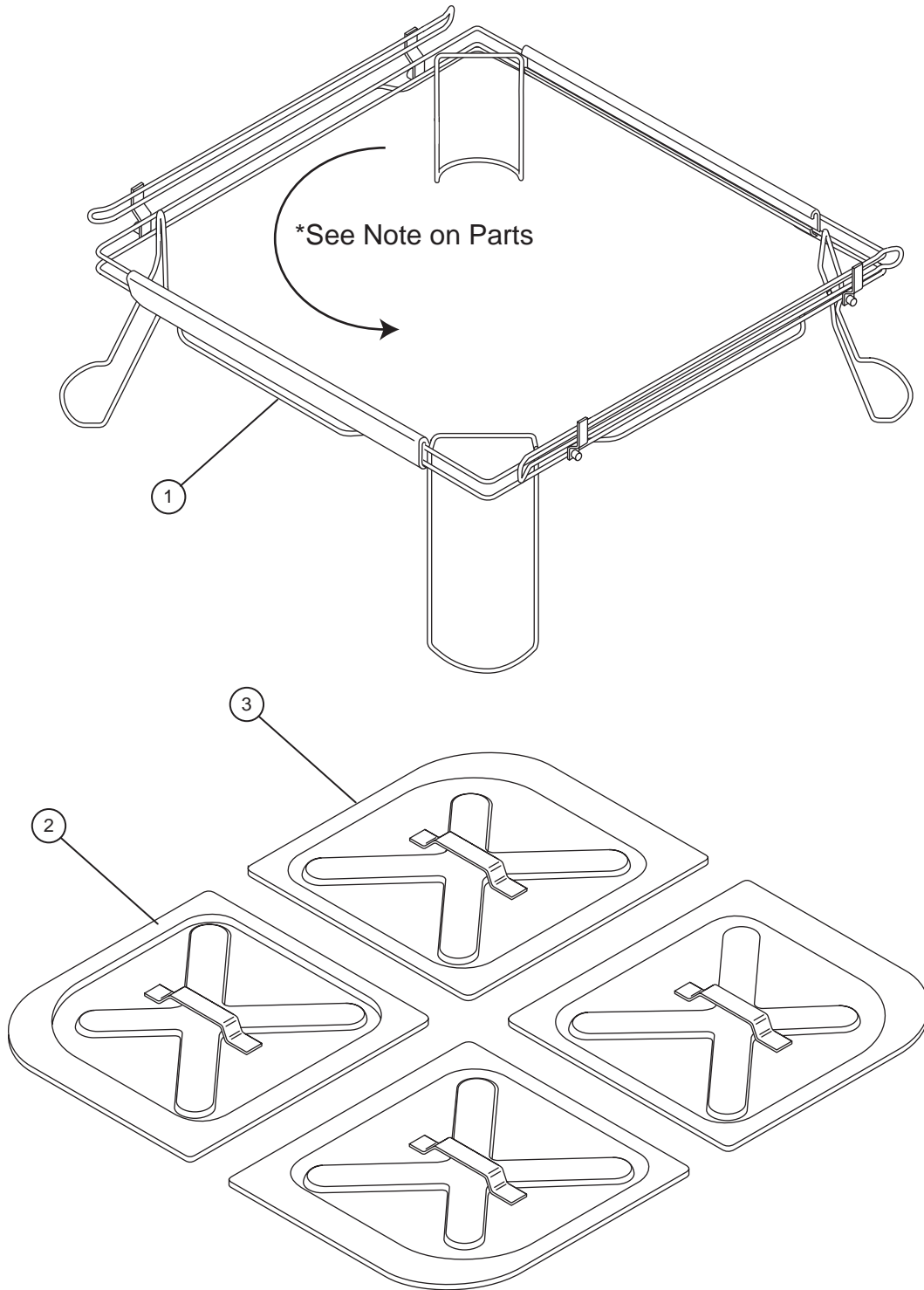

Figure 3.4- Tracks and Screens

HOOD AND TANK

Fig. 3.4

Item No.	Part No.	Part Description	Qty
* 1	C530238	Track Assembly	1
2	C332091sx	Left Screen	2
3	C332090dx	Right Screen	2

* In order to make a corner unit turn track frame so that rail moves to opposite side.

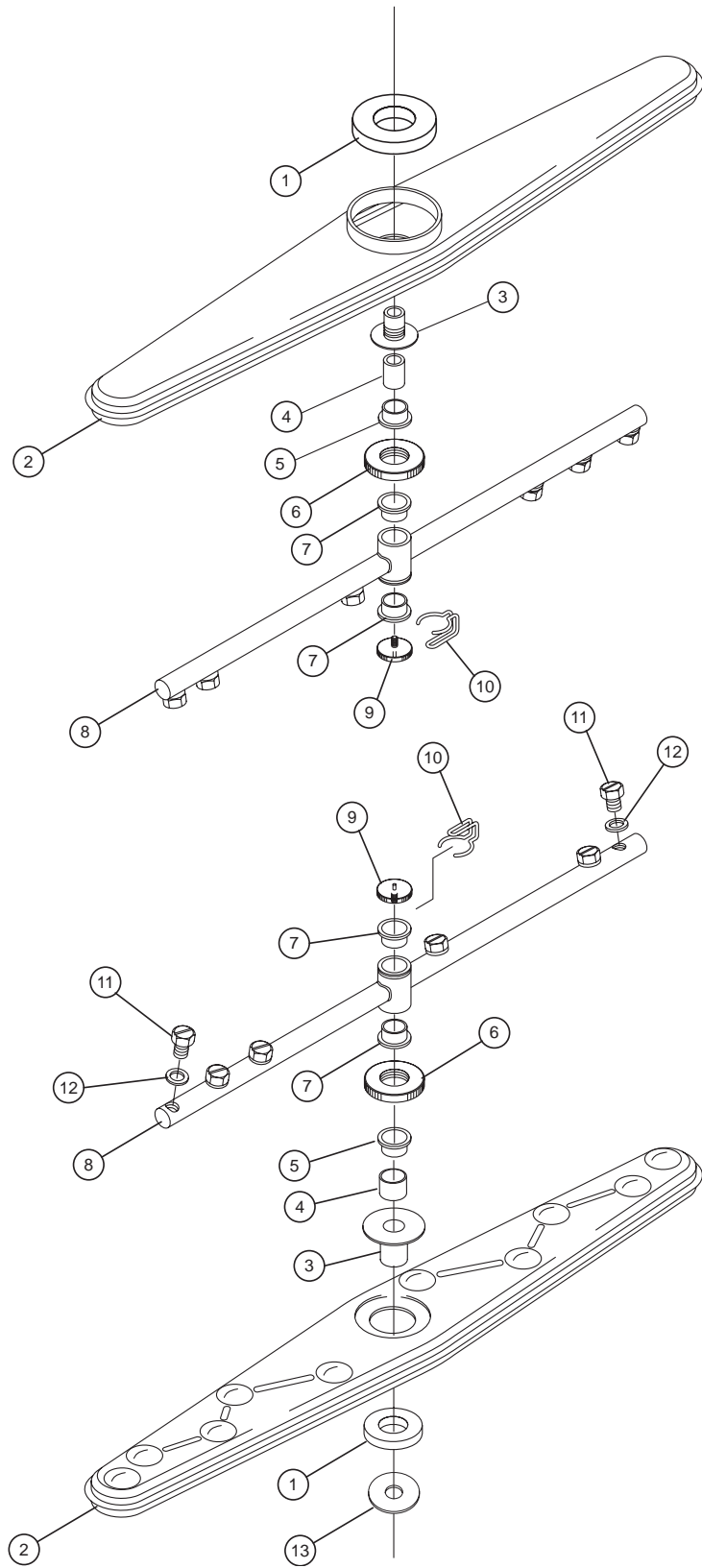

Figure 3.5- Wash and Rinse Spray Arms

WASH AND RINSE SPRAY ARMS

Fig. 3.5	Part		
Item No.	No.	Part Description	Qty
1	C191075	Washer	2
2	C420573	Wash Arm (Minus Items 1, 3-5)	2
3	C330824	Bearing	2
4	C190675	Spacer, Plastic	2
5	C190673	Bearing, Plastic	2
6	C280409	Spacer, Wash Arm	2
7	C190641	Bearing, Rinse Arm	4
8	C430346	Rinse Arm (Minus Items 7, 11, 12)	2
9	109837	Retaining Screw	2
10	C450218	Clip Retainer Nut	2
11	C380340	Nozzle Rinse Arm	6
12	C200809	O-ring Rinse Nozzle	6
13	C260568	Washer	2
	C420574	Wash Arm Complete (Includes Items 1-5)	
	C430316	Rinse Arm Complete (Includes Items 7-12)	

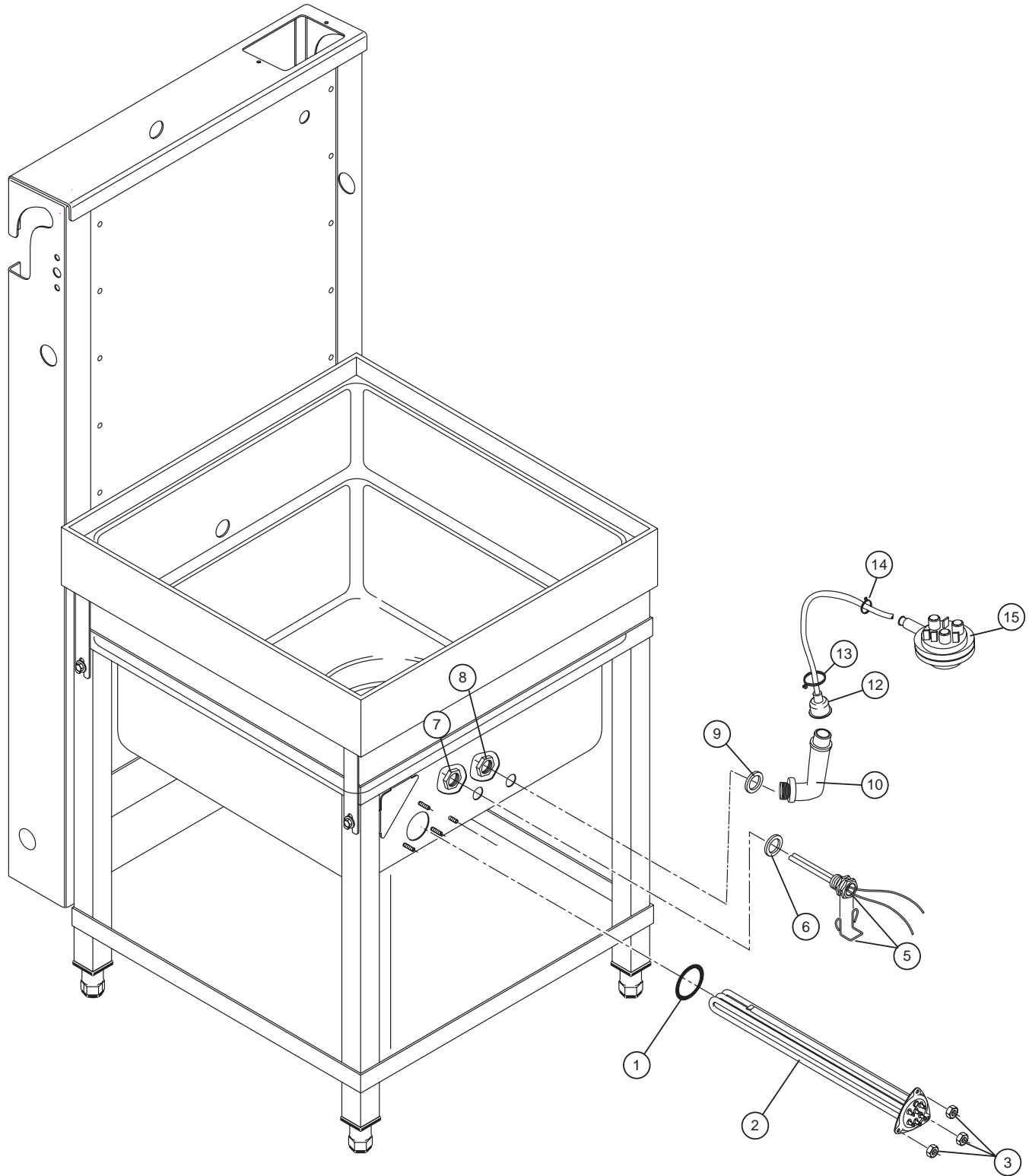

Figure 3.6- Wash Tank Components

WASH TANK COMPONENTS

Fig. 3.6 Item No.	Part No.	Part Description	Qty
1	109985	O-ring, Heater	1
2	C110226	Heater Element Wash Tank 3KW 230V	1
3	107420	Nut, Plain M6 SST	3
4	C161123	Heater Cap	1
5	C450516	Clip Retainer & Thermostat	1
6	C460502	Gasket, Thermostat	1
7	C270101	Nut, Thermostat	1
8	C270121	Nut, Air Trap	1
9	C200927	Gasket, Air Trap	1
10	C161310	Trap Air	1
11	0501519	Tie, Nylon Air Trap (Not Shown)	1
12	C161320	Hose, Moulded Air Trap	1
13	C450143	Clamp, Hose Air Trap	1
14	C450125	Clamp, Hose Air Trap	1
15	C130632	Switch, Pressure	1

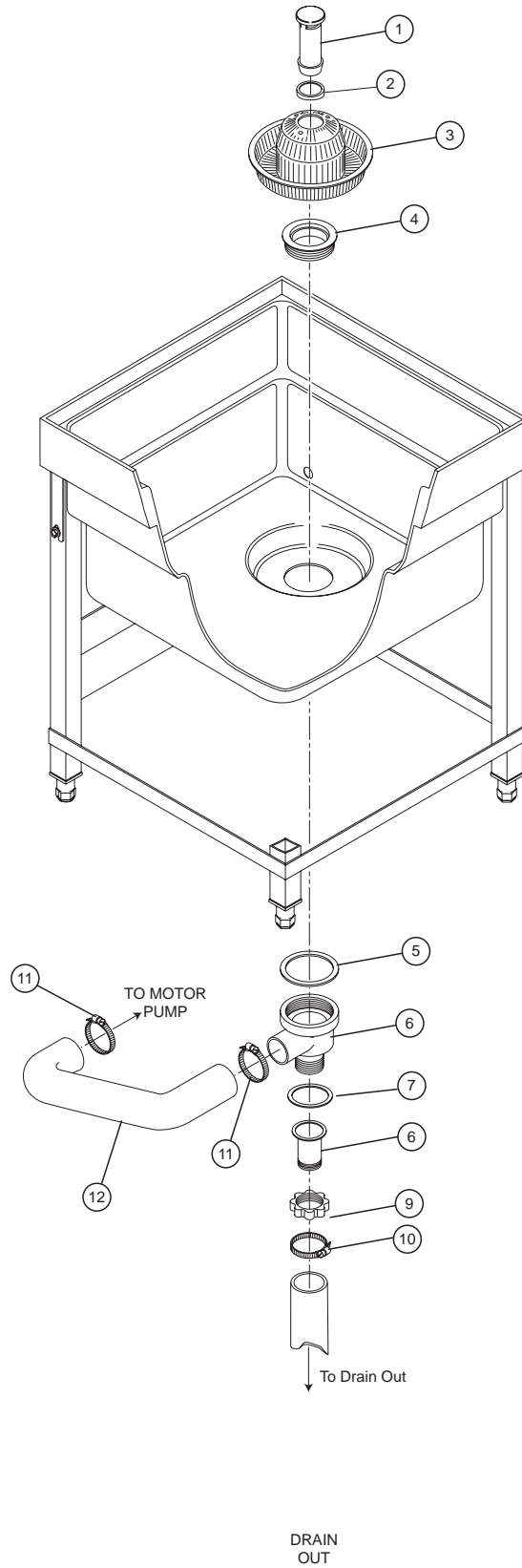

Figure 3.7- Drain Assembly

DRAIN ASSEMBLY

Fig. 3.7 Item No.	Part No.	Part Description	Qty
1	C180729	Tube, Overflow	1
2	C200950	Seal, Overflow Tube	1
3	C180818	Drain Basket Plastic	1
4	C180249	Flange Drain Plastic	1
5	C200817	Oring, Sump Tank	1
6	C180248	Sump Tank Plastic	1
7	107866	Gasket, Tailpiece	1
8	C106201	Tailpiece	1
9	107867	Nut, Tailpiece	1
10		Clamp, Hose	1
11	C450119	Clamp, Hose	3
12	C201056	Suction, Pump Hose	1

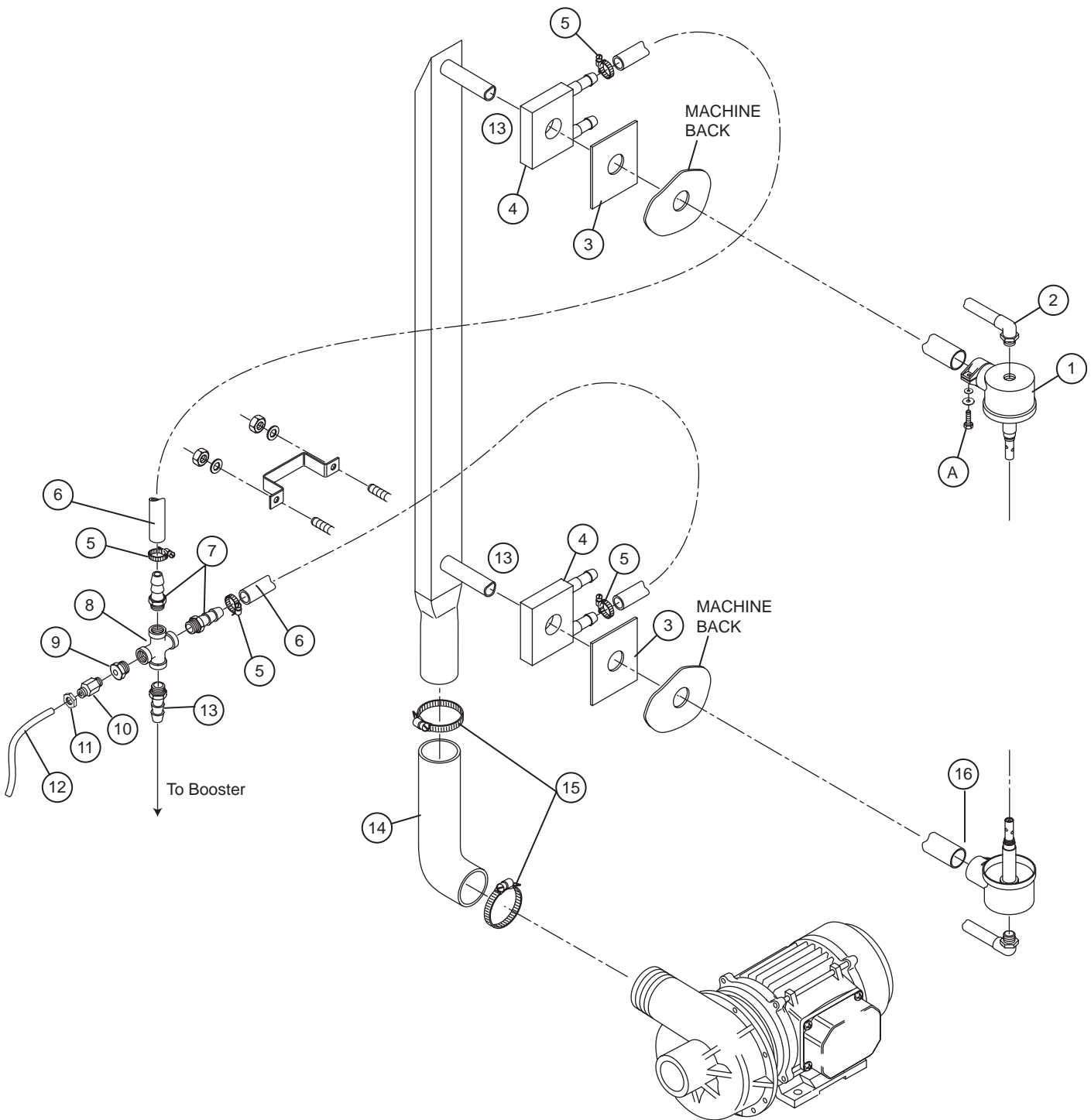

Figure 3.8- Wash and Rinse Piping

WASH AND RINSE PIPING

Fig. 3.8 Item No.	Part No.	Part Description	Qty
1	C190227	Spindle	2
2	C332526	Rinse Tube	2
3	C200955	Gasket	2
4	C191100	Wash Manifold Upper	2
5	C450103	Clamp, Hose	A/R
6	107417	Hose	A/R
7	0502651	Coupler, 1/2MPT x 1/2 Hose	2
8	C280312	Cross Fitting	1
9	C290125	Hose Barb	1
10	C190320	1
11	C180130	14
12	C160117	Hose	1
13	C200482	O-ring, Wash Manifold (Not Shown)	2
14	C201067	Discharge Pump Hose	1
15	C450119	Clamp, Hose	2
16	C190674	Spacer, Wash Manifold Lower	1
A	Hardware for Mounting Spindle (Quantities per Spindle)		
	C260151	Screw	1
	C260510	Lock washer	1
	C260502	Washer	1

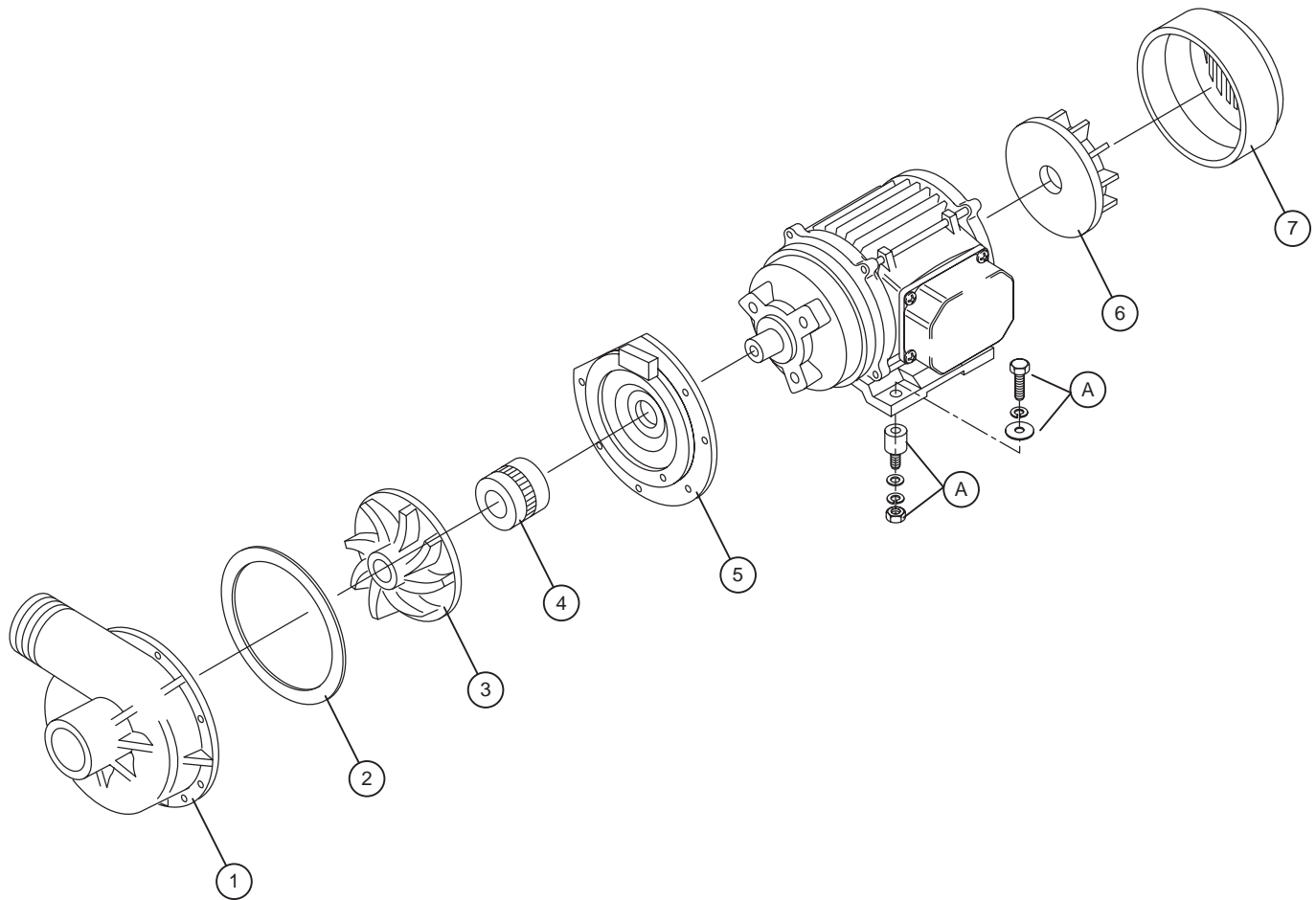

Figure 3.9- Wash Pump Assembly

WASH PUMP ASSMEBLY

Fig. 3.9	Part		
Item No.	No.	Part Description	Qty
1	109651	Pump Volute	1
2	109653	Pump Oring	1
3	C631654	Impeller	1
4	108002	Seal Pump	1
5	109649	Flange Assy 1HP	1
6	C630325	Fan Wash Pump Motor	1
7	C630255	Bell End Housing	1
A	Mounting Hardware for Pump Motor		
	C260104	Bolt	4
	C260513	Split Lock Washer	8
	C260538	Washer	8
	C441139	Absorbing Bolt	4
	110214	Nut, Dull M6	4
	109645	Pump Kit (Includes items 1-5)	A/R
	C100811	Complete Pump Assy 3PH (Includes Items 1-7 and Motor)	A/R
	C100812	Complete Pump Assy 1PH (Includes Items 1-7 and Motor)	A/R

* Pump Motor is not supplied as a separate component.

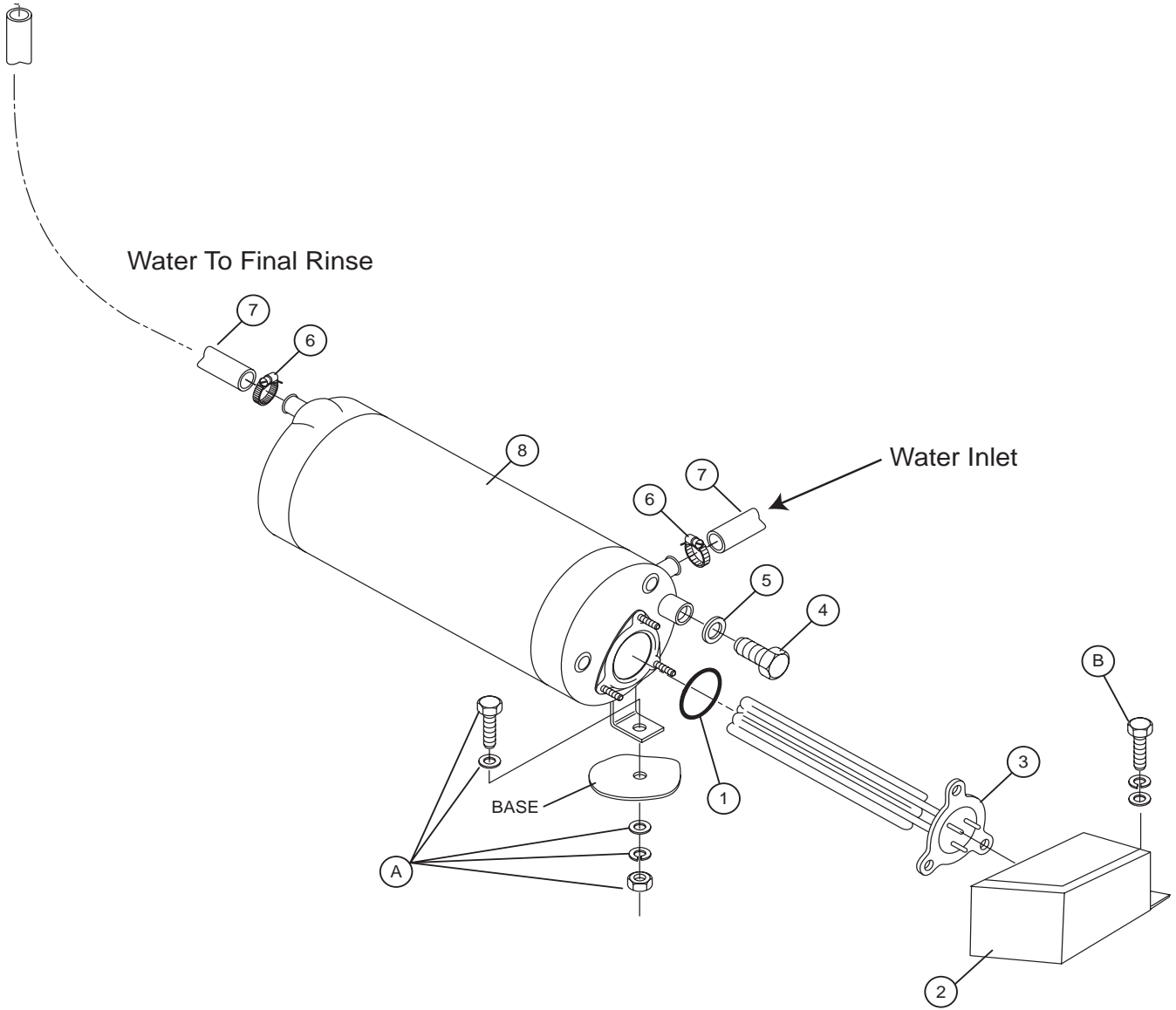

Figure 3.10- Booster Assembly

BOOSTER ASSEMBLY

Fig. 3.10 Item No.	Part No.	Part Description	Qty
1	109985	Seal, Electric Element	1
2	C322821	Element Cover	1
3	C110362	Heater 9Kw 208/240V 3PH 40° Rise	1
	C110392	Heater 14Kw 208/240V 3PH 70° Rise	1
4	C260112	Plug Booster Tank	1
5	108022	Washer, Plug	1
6	C450114	Clamp, Hose	A/R
7	C200104	Booster Hose	A/R
8	C330364	Booster Tank (Tank Only)	1
A	Mounting Hardware for Booster Tank		
	C260126	Bolt	1
	0501476	Washer 9/32 x 5/8 OD 18GA	2
	C260538	Washer	2
	110214	Nut, Dull M6	1
B	Mounting Hardware for Booster Element Cover		
	C260126	Bolt	2
	0501476	Washer 9/32 x 5/8OD 18GA	2
	C260503	Washer	2

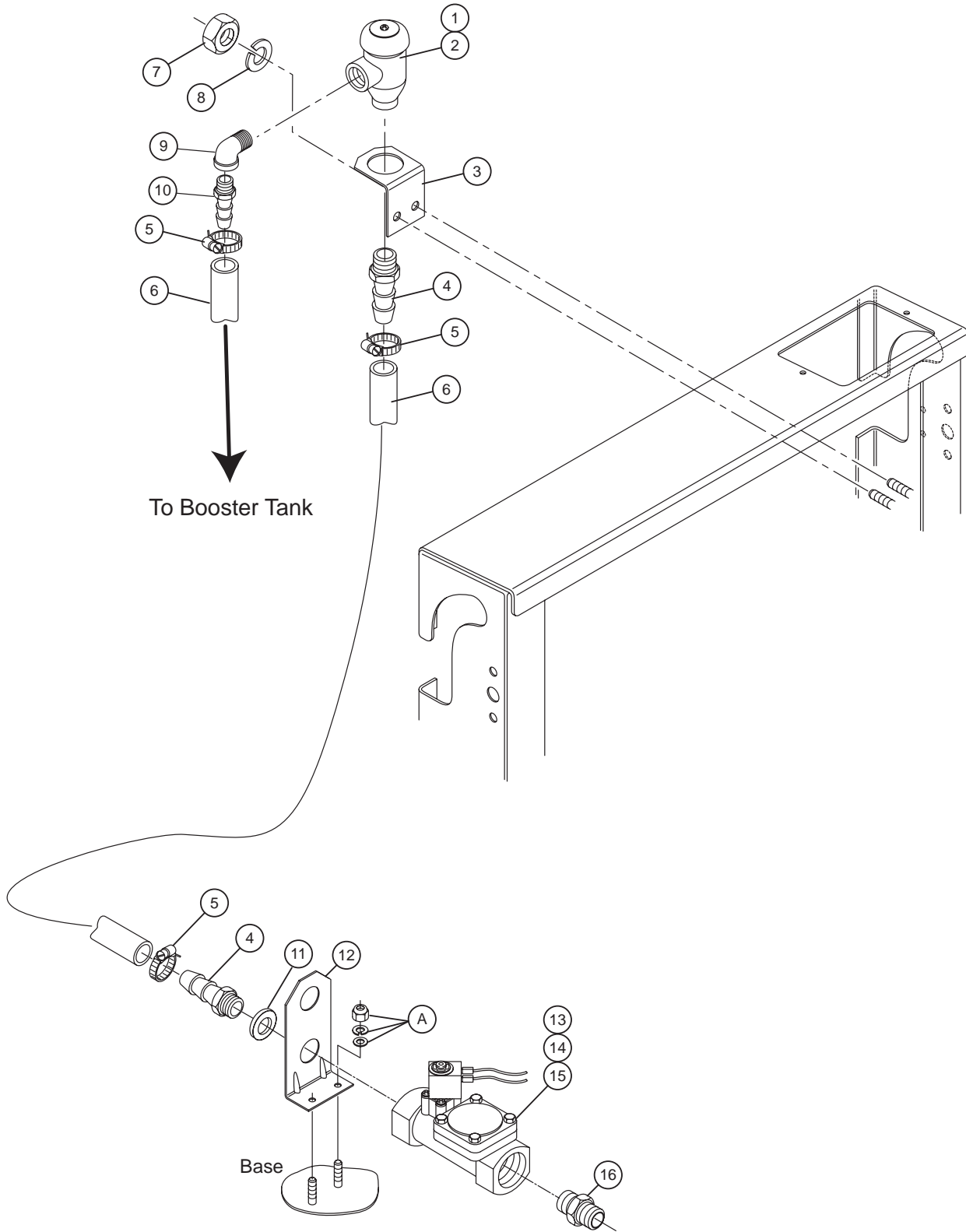

Figure 3.11- Water Inlet Piping

WATER INLET PIPING

Fig. 3.11 Item No.	Part No.	Part Description	Qty
1	100500	Vacuum Breaker 1/2"	1
2	108349	Repair Kit 1/2"	A/R
3		Bracket, Vacuum Breaker	1
4	C180312	Barb Fitting	2
5	C450114	Clamp, Hose	A/R
6	C200104	Booster Hose	A/R
7		Nut	2
8		Washer	2
9	C280123	Street Elbow	1
10	C290428	Barb Fitting	1
11	C330756	Valve Bracket	1
13	C121102	Valve Solenoid 240V	1
14		Repair Kit	A/R
15		Coil	A/R
16	C270308	Fitting	1
A	Mounting Hardware for Valve Bracket		
	C260512	Washer, Lock	2
	C260538	Washer	2
	110214	Nut, Dull M6	2

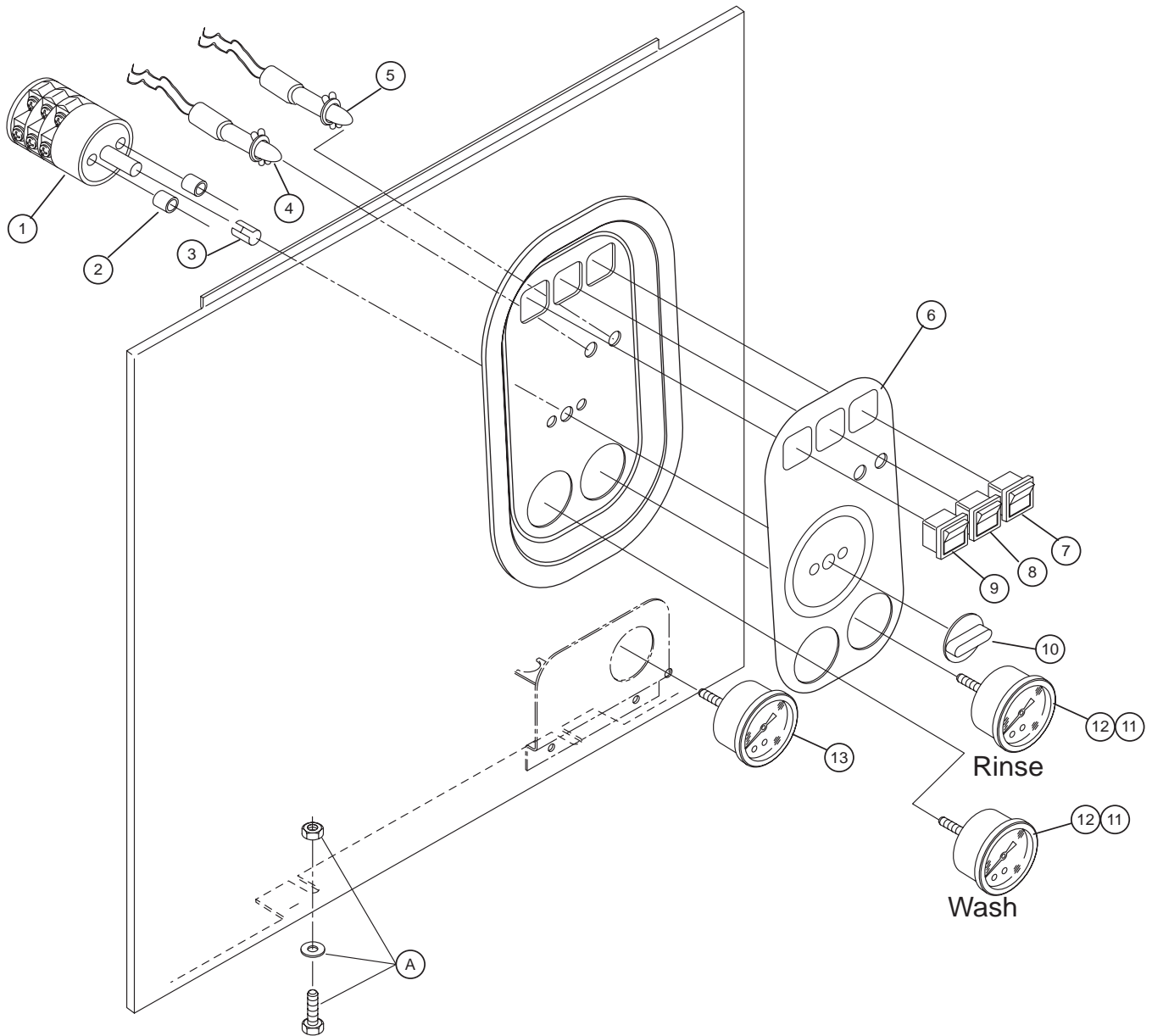

Figure 3.12- Control Panel

CONTROL PANEL

Fig. 3.12	Part		
Item No.	No.	Part Description	Qty
1	C120713	Selector Switch	1
2	C290821	Spacer, Selector Switch	2
3	C440817	Sleeve, Selector Switch	1
4	C130159	Lamp, Orange	1
5	C130157	Lamp, Green	1
--	C130707	Lens, Cover Clear (Not Shown)	2
6	C461314	Control Panel Decal (S/N Range W8100-W8135)	1
7	C130447	Switch, On/Off	1
8	C130484	Switch, Continous Wash	1
9	C130444	Switch, Manual Start	1
10	C450323	Knob, Selector Switch	1
11	C450905	Thermometer	2
12	C460344	Overlay	2
13	H441402	Pressure Gauge	1
A	Hardware for Mounting Control Panel		
	108441	Nut, Hex M5	2
	0501476	Washer 9/32 x5/8 OD 18GA	2
	C260129	Bolt	2

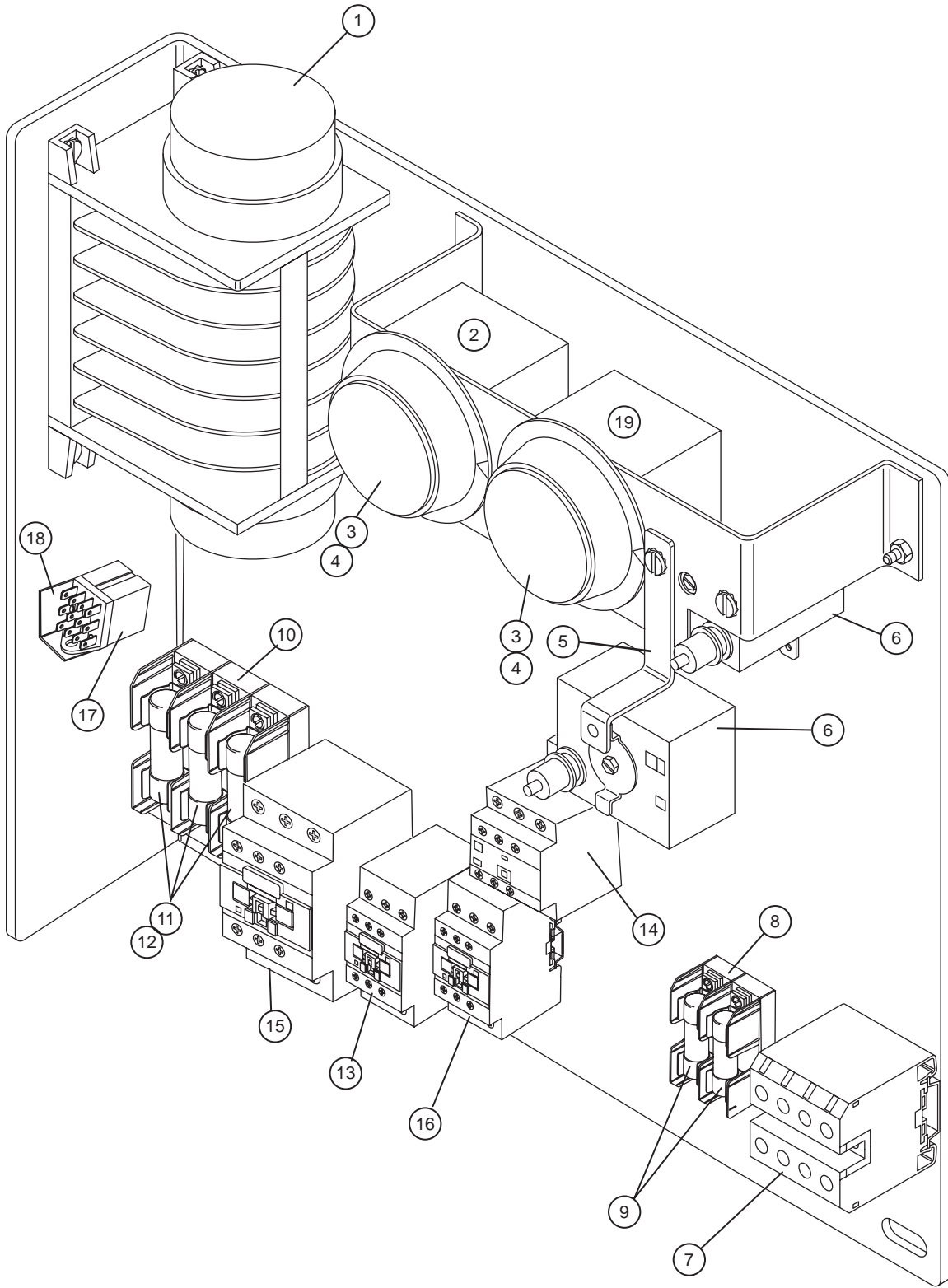

Figure 3.13- Control Cabinet

CONTROL CABINET

Fig. 3.13 Item No.	Part No.	Part Description	Qty
1	C121288	Timer Assembly Complete	1
2	C120501	Thermostat Tank	1
3	109952	Mounting Plate, Thermostat	2
4	109951	Knob, Thermostat	2
5	C350772	Bracket, Thermostat	1
6	C120519	Thermostat, Safety	2
7	C150231	Terminal Block	1
8	106402	Fuse Block 600V/30A 2P	1
9	111115	Fuse ATMR-2	2
10	106925	Fuse Block 600V/30A 3P	1
11	100917	Fuse ATMR-15 600V Time Delay (1 PH)	2
12	100913	Fuse ATMR-10 600V (3PH)	3
13	C120434	Contacto Tank Heat	1
14	108121	Motor Overload 3PH	1
14	107896	Motor Overload 1PH	1
15	C120462	Booster Contacter (3PH)	1
15	C120436	Booster Contacter (1PH)	1
16	C120438	Contacto Pump	1
17	C120459	Relay 16Amp 220V	1
18	C350796	Support, Relay	1
19	C36397	Thermostat, Booster	1
	C150833	Clamp, Cable (Not Shown)	1
	0501519	Tie, Nylon (Not Shown)	1
	C140209	Din Rail (Not Shown)	A/R

**This Page
Intentionally
Left
Blank**

PART 4:

ELECTRICAL

SCHEMATICS

**This Page
Intentionally
Left
Blank**

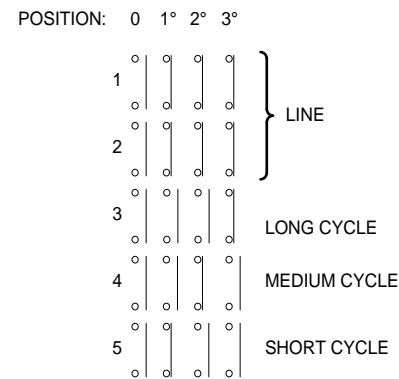
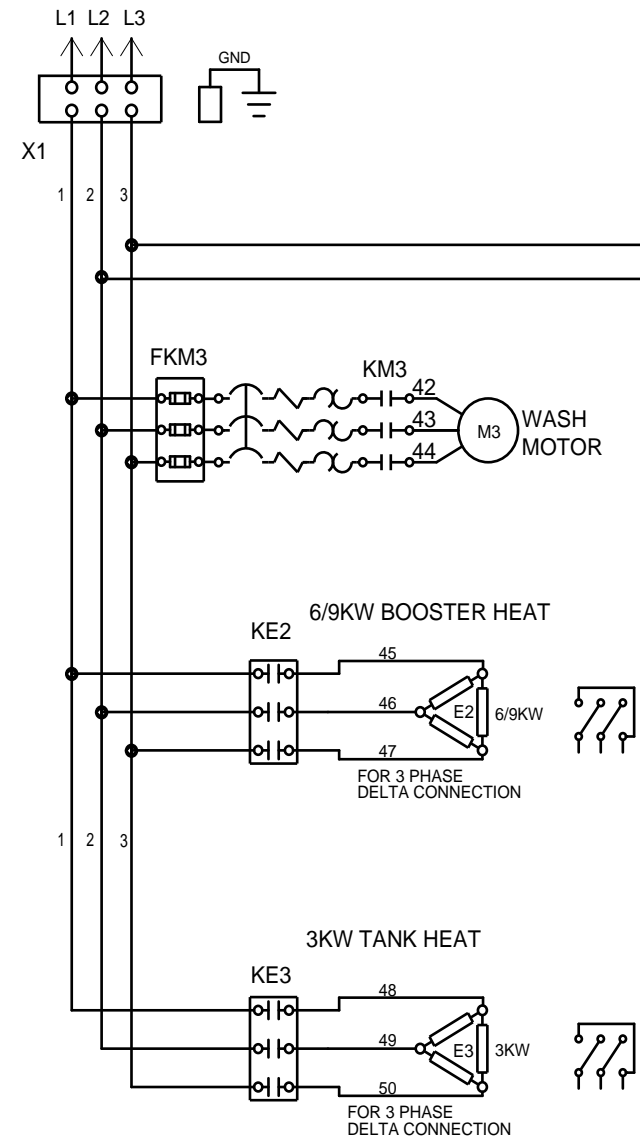

Q1 MAIN ROTARY SWITCH

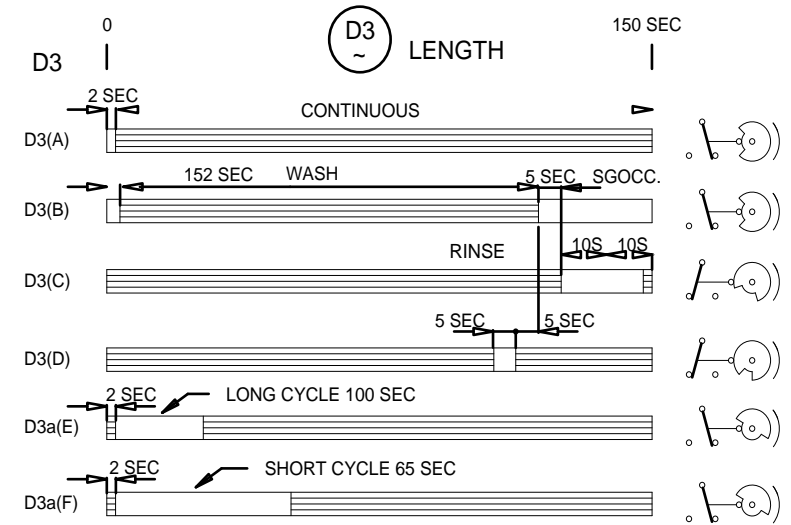
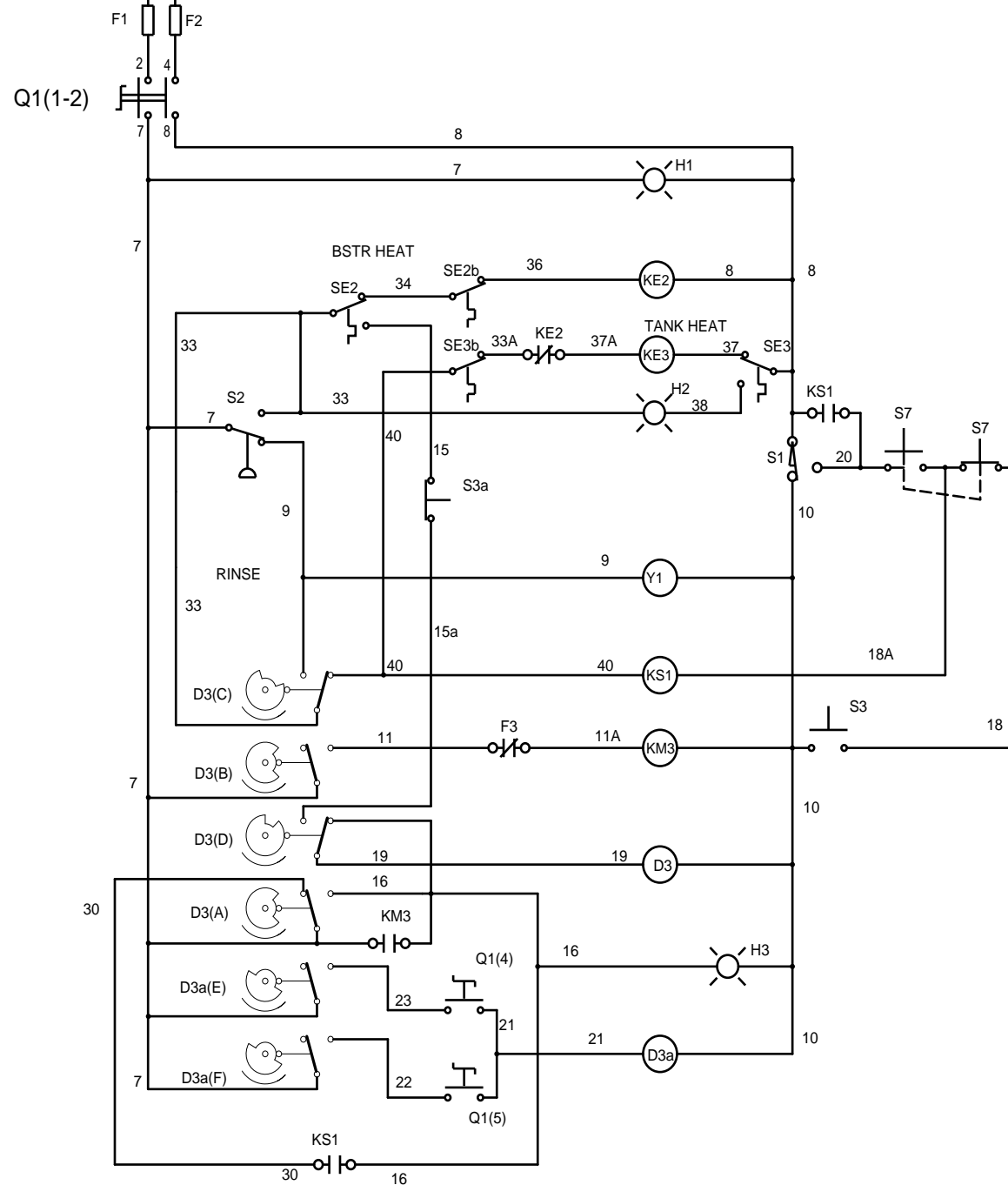

D3a SPEED

SYMBOL	DESCRIPTION
Q1	INTERRUPTEUR GENERAL MAIN SWITCH
S3	BOUTON DEMARRAGE START SWITCH
S7	INTERRUPTEUR AUTOMATIQUE/MANUEL AUTOMATIC/MANUAL SWITCH
S3a	INTERRUPTEUR POUR LAVAGE CONTINUEL SWITCH FOR CONTINUOUS WASH
H1	LAMPE TEMOIN SOUS TENSION INDICATOR LAMP
H2	LAMPE TEMOIN MACHINE PRETE INDICATOR LAMP MACHINE READY
H3	LAMPE TEMOIN FONCTIONNEMENT INDICATOR LAMP MACHINE RUNNING
KM3	CONTACTEUR POMPE PUMP CONTACTOR
KE2	CONTACTEUR RESISTANCE SURCHAUFFEUR BOILER HEATER CONTACTOR
KE3	CONTACTEUR RESISTANCE CUVE TANK HEATER CONTACTOR
KS1	RELAIS RELAY
D3	PROGRAMMATEUR TIMER
D3a	PROGRAMMATEUR TIMER
Y1	ELECTROVANNE SOLENOID VALVE
S1	MICROINTERRUPTEUR PORTE DOOR MICROSWITCH
X1	DOMINO JUNCTION
F	FUSIBLES FUSES
M3	ELECTROPOMPE PUMP
S2	PRESSOSTAT PRESSURE SWITCH
E2	RESISTANCE SURCHAUFFEUR BOILER HEATER
E3	RESISTANCE CUVE TANK HEATER
F3	TERMIQUE POUR POMPE DE LAVAGE WASH PUMP OVERLOAD RELAY
SE2	THERMOSTAT SURCHAUFFEUR BOILER THERMOSTAT
SE2b	THERMOSTAT SECURITE SURCHAUFFEUR BOILER SAFETY THERMOSTAT
SE3	THERMOSTAT CUVE TANK THERMOSTAT
SE3b	THERMOSTAT SECURITE CUVE TANK SAFETY THERMOSTAT

CUSTOMER TO SUPPLY RATED VOLTAGE/PHASE/Hz, AS SPECIFIED PER ORDER, TO DISCONNECT SWITCH. ALL POWER SUPPLIED TO EACH CONNECTION POINT MUST COMPLY WITH ALL LOCAL ELECTRIC CODES.				REV.	DESCRIPTION	ECN	DATE	BY	REV.	DESCRIPTION	ECN	DATE	BY
DR. BY	JMCALLISTER	SCALE	NA										
DATE	16APR03	SHEET	SH1 OF SH1										



**MH-65M2
3PHASE**
B 0501632 REV. 0

208/230V/1 - 60HZ

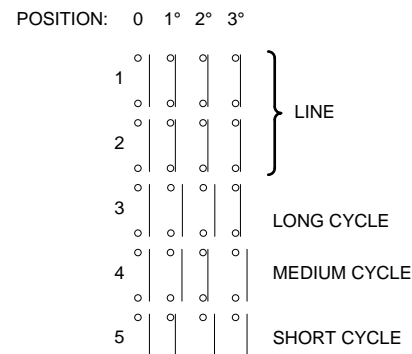
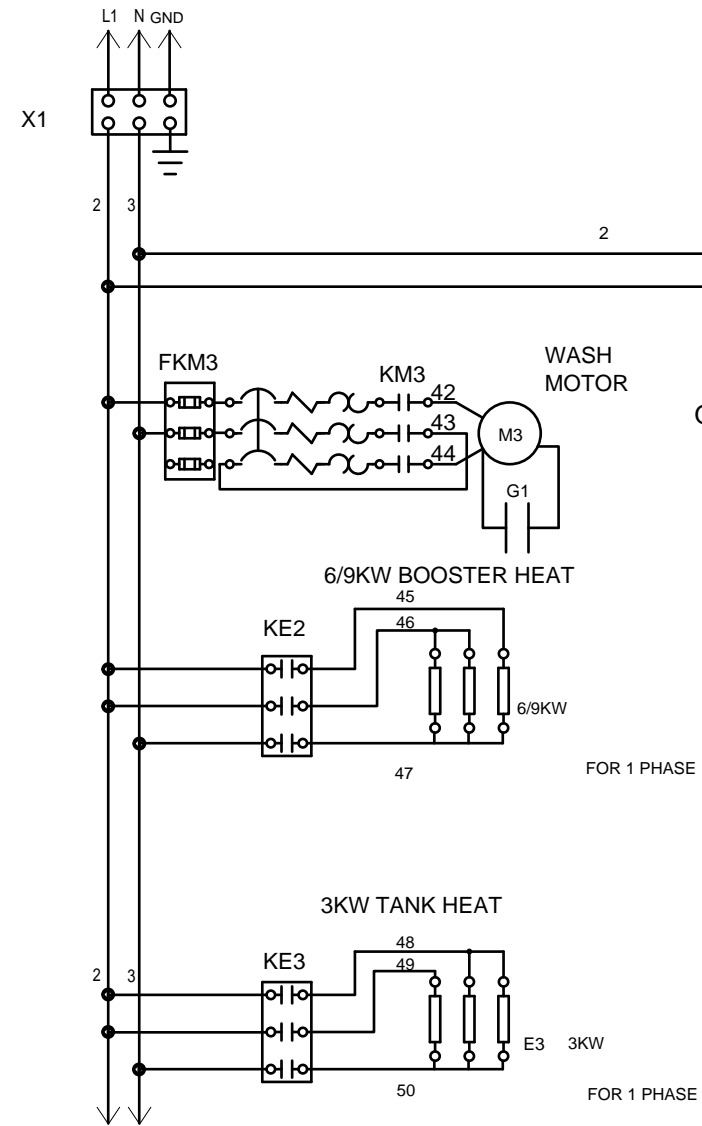

Q1 MAIN ROTARY SWITCH

Q1(1-2)

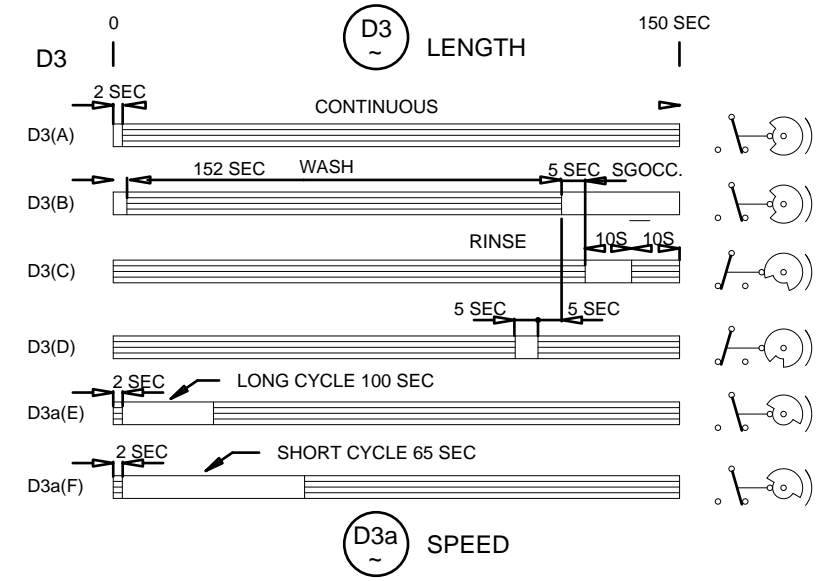
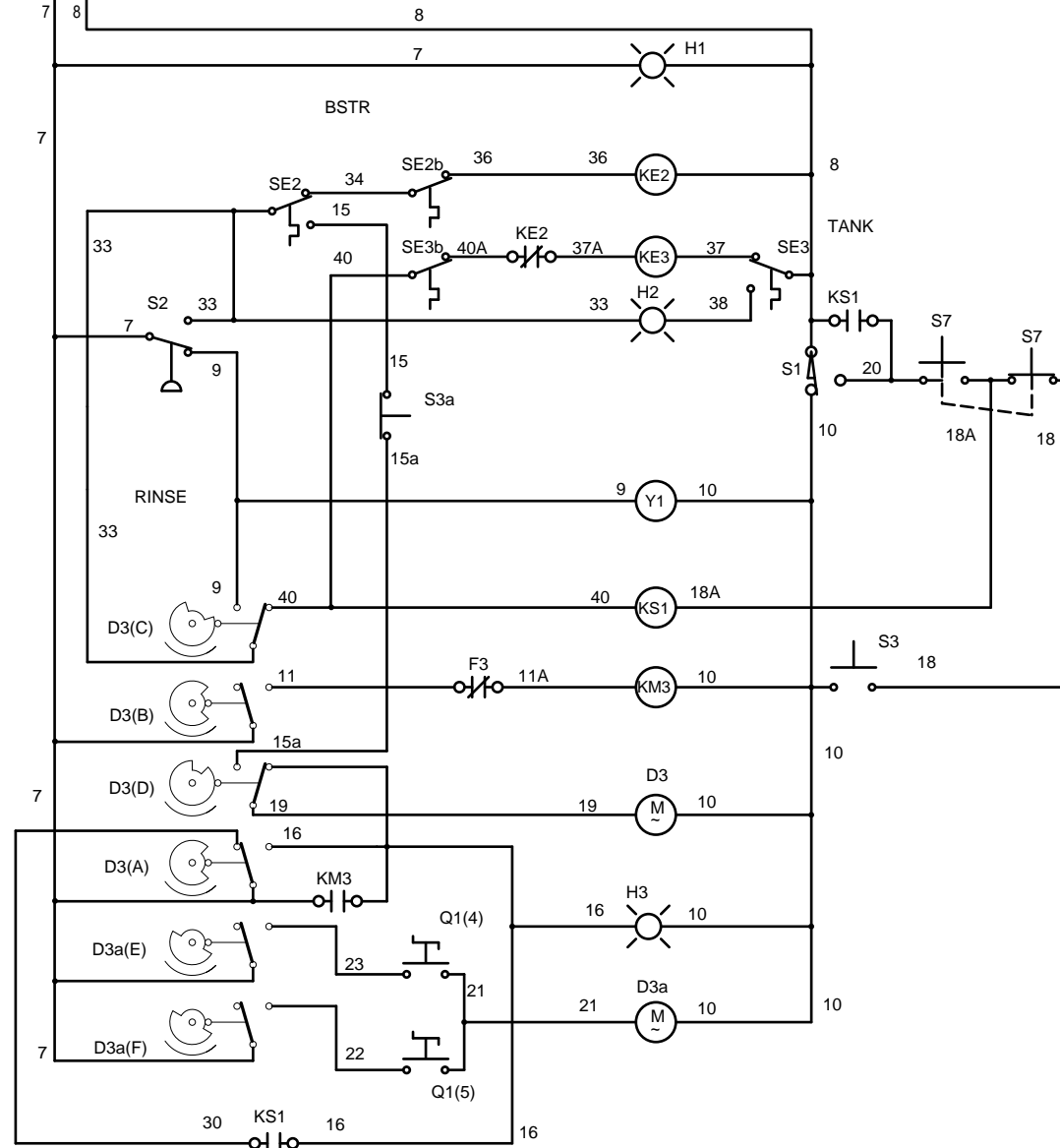

SYMBOL	DESCRIPTION
Q1	INTERRUPTEUR GENERAL MAIN SWITCH
S3	BOUTON DEMARRAGE START SWITCH
S7	INTERRUPTEUR AUTOMATIQUE/MANUEL AUTOMATIC/MANUAL SWITCH
S3a	INTERRUPTEUR POUR LAVAGE CONTINUUEL SWITCH FOR CONTINUOUS WASH
H1	LAMPE TEMOIN SOUS TENSION INDICATOR LAMP
H2	LAMPE TEMOIN MACHINE PRETE INDICATOR LAMP MACHINE READY
H3	LAMPE TEMOIN FONCTIONNEMENT INDICATOR LAMP MACHINE RUNNING
KM3	CONTACTEUR POMPE PUMP CONTACTOR
KE2	CONTACTEUR RESISTANCE SURCHAUFFEUR BOILER HEATER CONTACTOR
KE3	CONTACTEUR RESISTANCE CUVE TANK HEATER CONTACTOR
KS1	RELAIS RELAY
D3	PROGRAMMATEUR TIMER
D3a	TIMER
Y1	ELECTROVANNE SOLENOID VALVE
S1	MICROINTERRUPTEUR PORTE DOOR MICROSWITCH
X1	DOMINO JUNCTION
F	FUSIBLES FUSES
M3	ELECTROPOMPE PUMP
S2	PRESSOSTAT PRESSURE SWITCH
E2	RESISTANCE SURCHAUFFEUR BOILER HEATER
E3	RESISTANCE CUVE TANK HEATER
F3	TERMIQUE POUR POMPE DE LAVAGE WASH PUMP OVERLOAD RELAY
SE2	THERMOSTAT SURCHAUFFEUR BOILER THERMOSTAT
SE2b	THERMOSTAT SECURITE SURCHAUFFEUR BOILER SAFETY THERMOSTAT
SE3	THERMOSTAT CUVE TANK THERMOSTAT
SE3b	THERMOSTAT SECURITE CUVE TANK SAFETY THERMOSTAT

CUSTOMER TO SUPPLY RATED VOLTAGE/PHASE/Hz, AS SPECIFIED PER ORDER, TO DISCONNECT SWITCH. ALL POWER SUPPLIED TO EACH CONNECTION POINT MUST COMPLY WITH ALL LOCAL ELECTRIC CODES.				REV.	DESCRIPTION	ECN	DATE	BY	REV.	DESCRIPTION	ECN	DATE	BY
DR.BY	JMCALLISTER	SCALE	NA										
DATE	16APR03	SHEET	SH1 OF SH1										



MH-65
1-PHASE

B 0510633 REV. **0**

