

# Champion®

The Dishwashing Machine Specialists

Project \_\_\_\_\_  
Item No. \_\_\_\_\_  
Quantity \_\_\_\_\_

TABLE SYSTEMS

## STANDARD FEATURES

- Compact, flexible design 90° or 180° to fit high volume operations
- Quality stainless steel construction
- Fully-automatic operation
- Extend the drying space for clean wares and save operator steps
- Easy-to-reach rack storage
- Sloped drain
- Cantilever load table – load racks from the front, offering layout flexibility and saving valuable space
- Optional hood for splash protection, cantilever tables are available with an optional stainless steel hood with vent cowl opening
- Optional table limit switch

## TABLE SYSTEMS

For Rack Conveyor Series  
Dishwashing Machines



90° Corner  
Conveyor Table

Also available  
180° Corner  
Conveyor Table



64 RCT Table

Champion Industries, Inc.  
2674 N. Service Road  
Jordan Station, Ontario, Canada L0R 1S0  
Tel: 905/562-4195 Fax: 905/562-4618

Champion Industries, Inc.  
3765 Champion Blvd., Winston-Salem, NC 27105  
Tel: 800/532-8591 Fax: 336/661-1979  
[www.championindustries.com](http://www.championindustries.com)

# TABLE SYSTEMS

For Rack Conveyor Series  
Dishwashing Machines

# Champion®

The Dishwashing Machine Specialists

## 90° Corner Conveyor Table

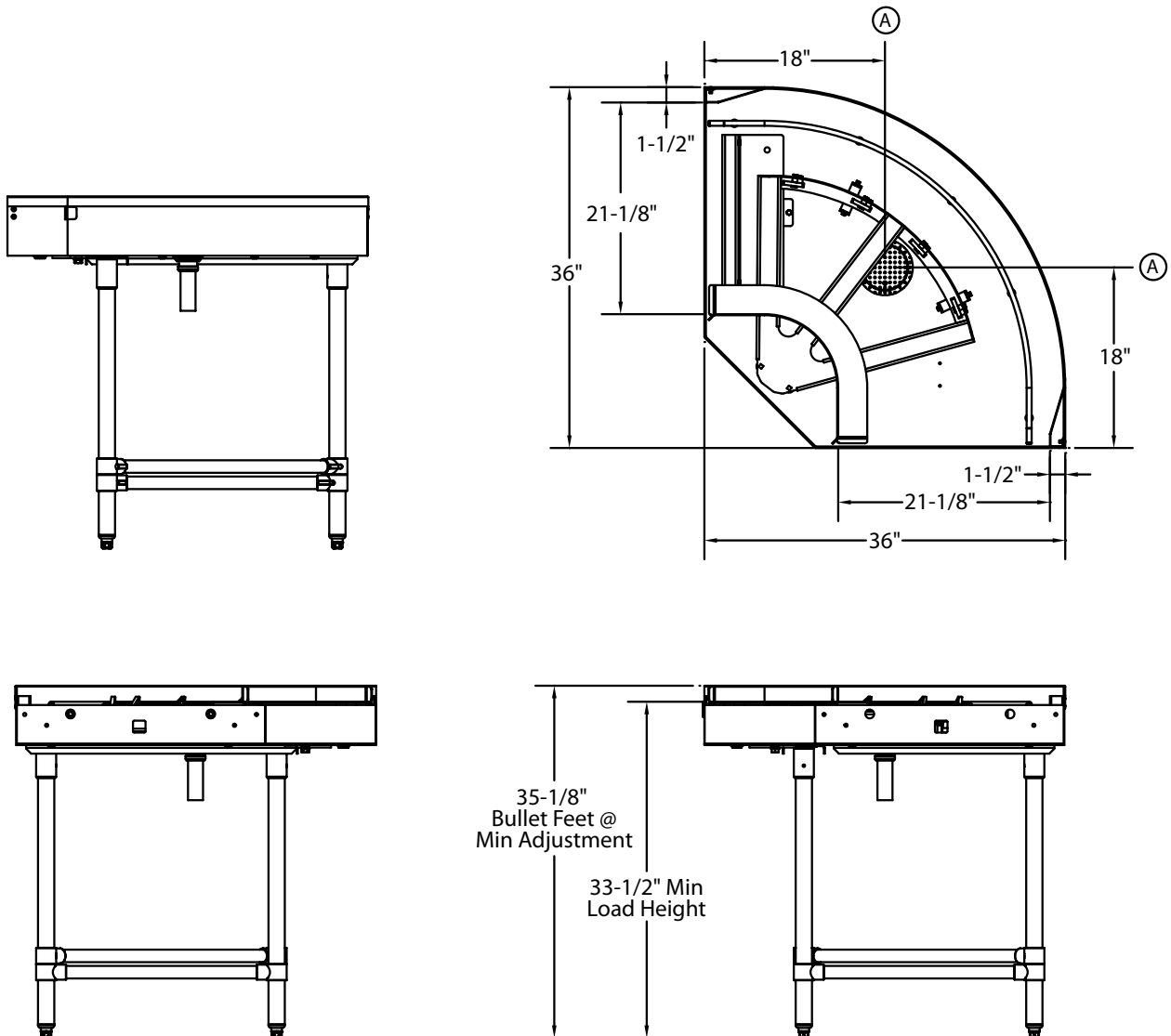

<b>180° CCT</b>	<b>64 RCT</b>
Shipping weight: <b>300 lbs.</b>	Shipping weight: <b>180 lbs.</b>
Volume crated: <b>107 cu. ft.</b>	Volume crated: <b>60 cu. ft.</b>
<b>90° CCT</b>	<b>84 RCT</b>
Shipping weight: <b>250 lbs.</b>	Shipping weight: <b>200 lbs.</b>
Volume crated: <b>47 cu. ft.</b>	Volume crated: <b>72 cu. ft.</b>

**Note:** 90° and 180° CCT must be ordered with roller conveyor table.

# TABLE SYSTEMS

For Rack Conveyor Series  
Dishwashing Machines

**Champion**<sup>®</sup>  
The Dishwashing Machine Specialists

## 180° Corner Conveyor Table

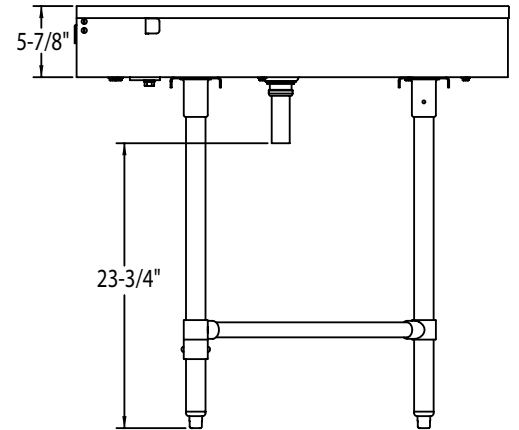
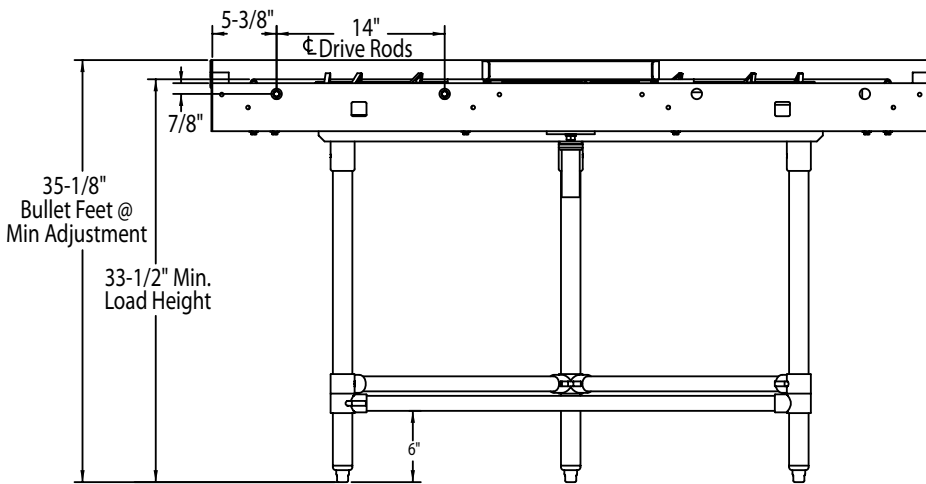
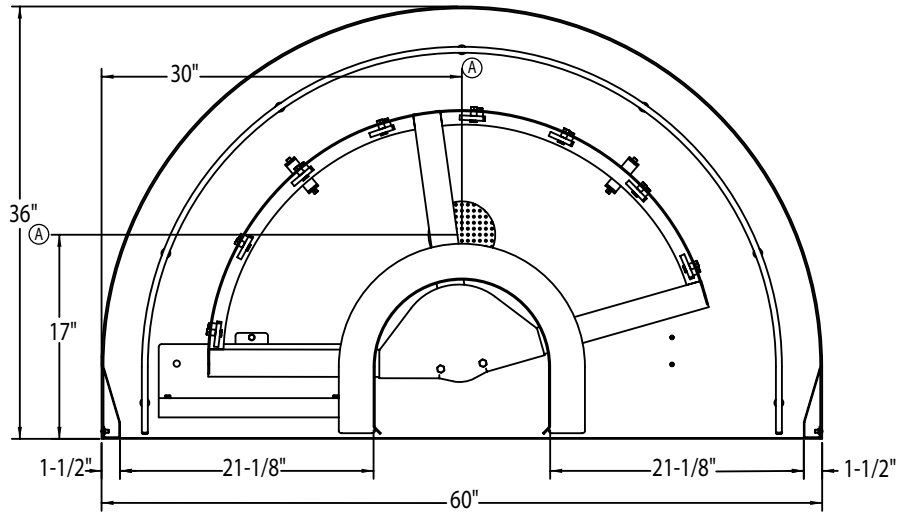

### Utilities

- |          |                               |
|----------|-------------------------------|
| <b>A</b> | <b>Drain</b>                  |
| <b>A</b> | 1-1/2" O.D. connection on CCT |

Due to an ongoing value analysis program at Champion, specifications contained in this catalog are subject to change without notice.

Champion Industries, Inc., 3765 Champion Blvd., Winston-Salem, NC 27105 • 800/532-8591 • Fax: 336/661-1979 • www.championindustries.com  
2674 N. Service Road, Jordan Station, Ontario, Canada L0R 1S0 • 905/562-4195 • Fax: 905/562-4618

# TABLE SYSTEMS

For Rack Conveyor Series  
Dishwashing Machines

# Champion<sup>®</sup>

The Dishwashing Machine Specialists

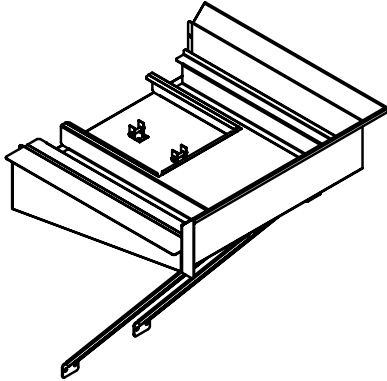

## 30" Cantilever Sideloader For 20" racks up to 30" long

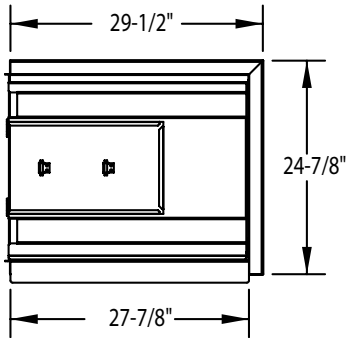

Plan View

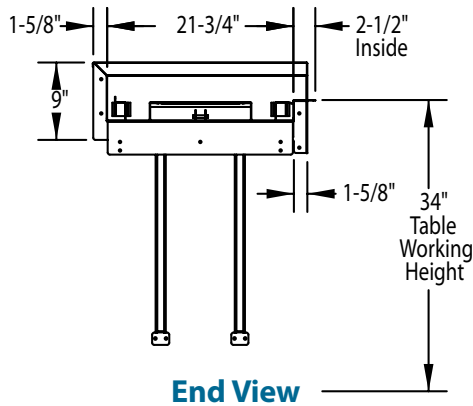

End View

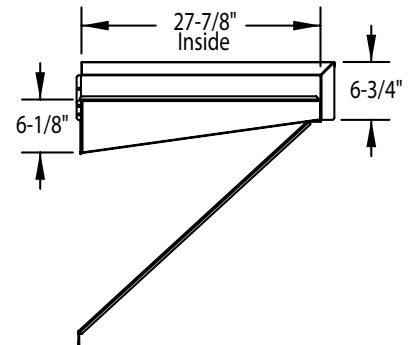

Side View

## 24" Cantilever Sideloader For standard 20" x 20" racks

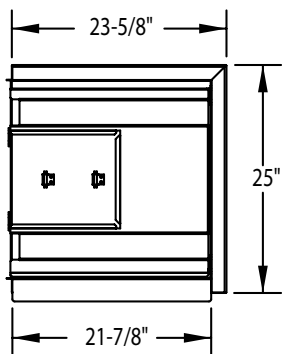

Plan View

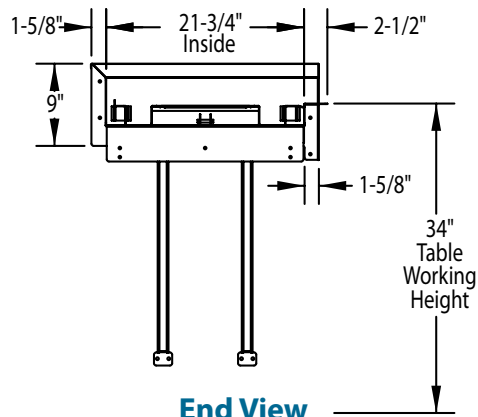

End View

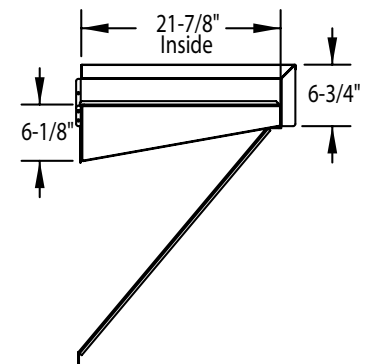

Side View

Due to an ongoing value analysis program at Champion, specifications contained in this catalog are subject to change without notice.

Champion Industries, Inc., 3765 Champion Blvd., Winston-Salem, NC 27105 • 800/532-8591 • Fax: 336/661-1979 • www.championindustries.com  
2674 N. Service Road, Jordan Station, Ontario, Canada L0R 1S0 • 905/562-4195 • Fax: 905/562-4618